



All in one

Control Connect



EN Instruction Manual

pH
ORP

°C

VSP

Wi Fi

BLUETOOTH



Control Panel for swimming pools

76752 CONTROL CONNECT ALL IN ONE
77420 KIT DRIVER VSP C.C.ALL IN ONE
77584 LEVEL SENSOR AND SUCTION KIT

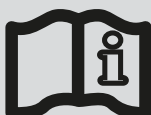

TABLE OF CONTENTS

| | |
|--|-----------|
| Quick Guide | 4 |
| 1. General Information | 9 |
| 1.1 General Characteristics | 9 |
| 1.2 Safety Warnings and Recommendations | 10 |
| 1.3 Contents | 11 |
| 1.4 Specifications | 12 |
| 1.5 Dimensions | 13 |
| 2. Control Panel Installation | 13 |
| 2.1 Wall Mounting | 13 |
| 2.2 Access to Panel Sections | 14 |
| 2.3 General Hydraulic Installation Diagram | 15 |
| 3. Panel Sections and Connections | 16 |
| 3.1 Electronic Board | 17 |
| 3.2 Electrical Connections – 230 Vac and R1–R4 Outputs (Configuration 1 and 2) | 18 |
| 3.3 Sensors and Control Components | 20 |
| 4. Initial Start-up and Installation of Components | 21 |
| 4.1 Control Panel Inlet and Outlet Valve General Installation Diagram | 21 |
| 4.2 Panel Inlet and Outlet Connections | 22 |
| 4.3 Valve Installation | 23 |
| 4.4 pH and Cl ₂ Peristaltic Pump Connection and Level Sensor Installation | 24 |
| 4.5 Injection Point Installation | 25 |
| 4.6 pH and ORP Sensor Installation | 26 |
| 4.7 Inductive Flow Sensor | 27 |
| 4.8 Initial Start-up | 28 |
| 5. User Interface | 28 |
| 5.1 Cover and Functions | 28 |
| 5.2 Home Screen and Access to Panel Features | 29 |
| 5.3 Temperature Sensor Configuration | 30 |
| 5.4 pH Configuration | 32 |
| 5.5 Log menu | 34 |
| 5.6 Configuration Menu | 35 |
| 5.7 Information Menu | 37 |
| 5.8 Relays Menu (Fluidra Pool) | 38 |
| 5.9 ClmV Configuration | 40 |
| 6. Sensor Calibration (pH, ORP, temperature) | 42 |
| 6.1 Fast pH Calibration | 42 |
| 6.2 Standard pH Calibration | 42 |
| 6.4 T (°C/°F) Calibration | 43 |
| 6.3 Standard ClmV Calibration (ORP) | 43 |
| 7. Alarms | 44 |
| 7.1 Temperature Sensor Alarm | 45 |
| 7.2 Inductive/Flow Switch Sensor Alarm | 45 |
| 7.3 pH Alarms | 46 |
| 7.4 ORP (mV) High/Low Alarm | 48 |
| 7.5 Basic Troubleshooting | 49 |
| 8. Maintenance | 50 |
| 9. Appendices | 51 |
| 10. Warranty | 57 |



NOTICE

The short manual included with this product only contains essential information on safety measures that must be implemented during installation, maintenance and start-up.



The complete manual can be read and downloaded as a PDF file using the QR or from the following website: www.astralpool.com. All assembly, electrical installation and maintenance tasks are to be carried out by authorised, qualified technicians who have carefully read all the installation and service instructions.

GENERAL CHARACTERISTICS

- Smart controllers make maintenance and monitoring of the pool efficient and cost-effective.
- Compatible with saline electrolysis systems.
- Maintaining a certain level of chlorine in the pool water guarantees its quality.
- The controller will release doses of chlorine when the pool's filtering system (pump and filter) are running.
- The equipment has several safety devices which are activated in the event of a system malfunction, as well as a control micro-controller.
- These control systems include automatic pH and ORP controllers which are activated according to need.

SAFETY WARNING AND RECOMMENDATIONS

- Installation and manipulation should only be performed by suitably qualified technicians.
- Applicable standards for prevention of accidents and for electrical installations must be respected. During installation, bear in mind that electrically disconnecting the equipment requires a switch or circuit breaker according to standards IEC 60947-1 and IEC 60947-3 which ensures an omnipolar cut-off, directly connected to the power supply terminals and with a contact separation in all poles, providing total disconnection under overvoltage category III conditions, in an area that fulfils the safety requirements of the site. The switch must be located in the immediate vicinity of the equipment and must be easily accessible. Additionally, it must be marked as the equipment's disconnection element.
- The equipment must be fed from a residual current device (RCD) not exceeding 30mA. The equipment must be earthed.
- The installation must comply with the requirements of IEC / HD 60364-7-702 and national standards applicable to swimming pools.
- The manufacturer accepts no responsibility for assembly, installation or setting up, nor for any manipulation or addition of components other than when carried out at the manufacturer's premises.
- This appliance is not intended for use by persons (including children) with reduced physical, sensory or mental capabilities, or who lack experience or knowledge, unless they have been given supervision or instruction concerning use of the appliance by a person responsible for their safety. Children should be supervised to ensure that they do not play with the appliance.
- The control unit operates at 230 Vac / 50 Hz. Do not attempt to alter the power supply to operate at any other voltage.
- Ensure that all electrical connectors are properly tightened, to avoid bad connections leading to overheating.
- Before installing or replacing any system component, ensure that the system has been disconnected from the power supply and that no water is flowing through it. Only use genuine replacement parts.
- Since the equipment generates heat, it is important to install it in a sufficiently ventilated place and to keep the ventilation openings free of any obstructions. Do not install near flammable materials.
- The control panel has an IP45 rating. Never install it in areas at risk of flooding.
- This equipment must be permanently connected to the water supply and should not be connected using a temporary supply.
- This device is equipped with a mounting bracket; see installation instructions.
- Keep this Instruction Manual for future reference.
- Please read the instruction manual before continuing to install the equipment



All assembly, electrical installation and maintenance work is to be carried out by authorised, qualified technicians who have carefully read all the installation and maintenance instructions.

Components and installation

76752 CONTROL CONNECT ALL IN ONE

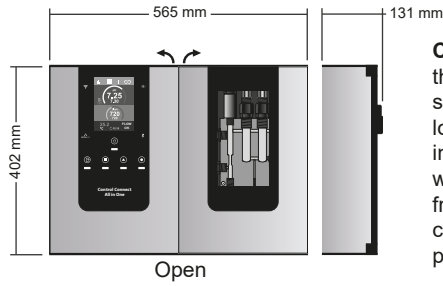

CAUTION: Always install the equipment on a firm surface in a dry, ventilated location. We recommend installing the equipment where it will be protected from the weather. Avoid creating corrosive atmospheres.

Wall mounting

Screws and wall plugs not supplied
Wall plug: 7 x 35 mm
Screw: 5 x 35 mm

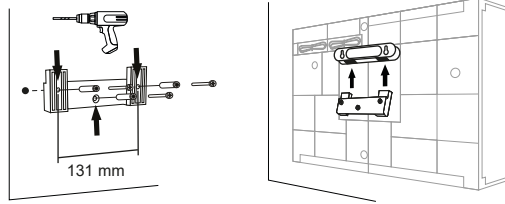

For further information on installation and wiring, see complete manual.

Accessories

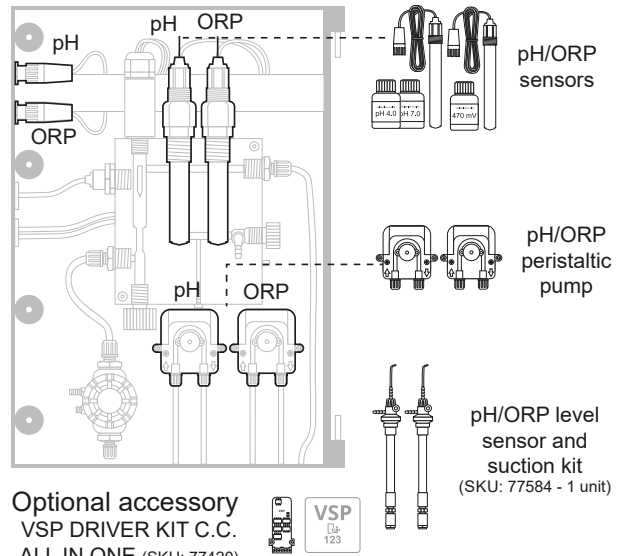

Optional accessory
VSP DRIVER KIT C.C.
ALL IN ONE (SKU: 77420)

Connection

Control Connect ALL IN ONE

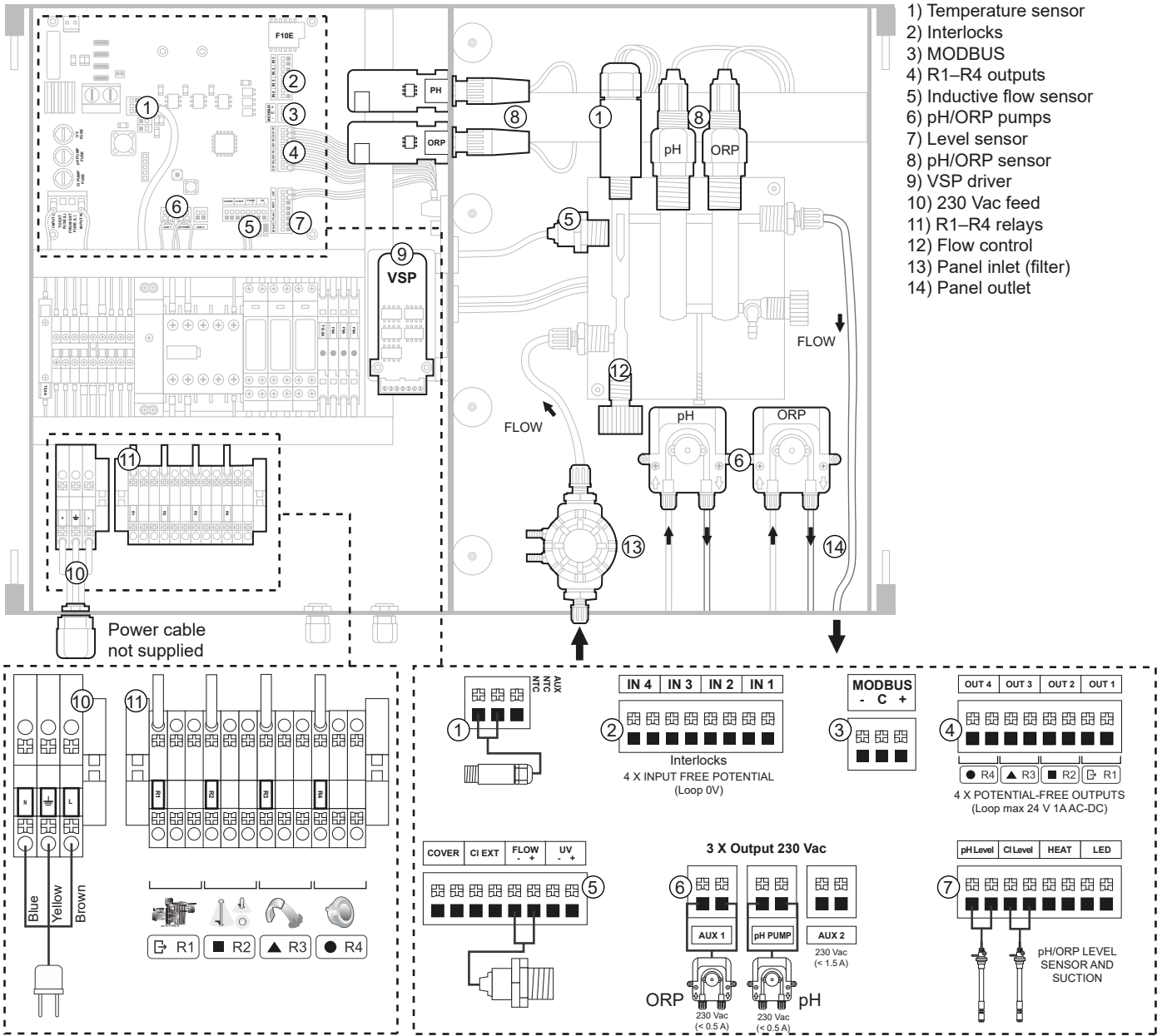

- 1) Temperature sensor
- 2) Interlocks
- 3) MODBUS
- 4) R1-R4 outputs
- 5) Inductive flow sensor
- 6) pH/ORP pumps
- 7) Level sensor
- 8) pH/ORP sensor
- 9) VSP driver
- 10) 230 Vac feed
- 11) R1-R4 relays
- 12) Flow control
- 13) Panel inlet (filter)
- 14) Panel outlet

Power cable not supplied

R1 R2 R3 R4

3 X Output 230 Vac

ORP 230 Vac (< 0.5 A) pH 230 Vac (< 0.5 A)

pH Level CI Level HEAT LED

pH/ORP LEVEL SENSOR AND SUCTION

General installation diagram

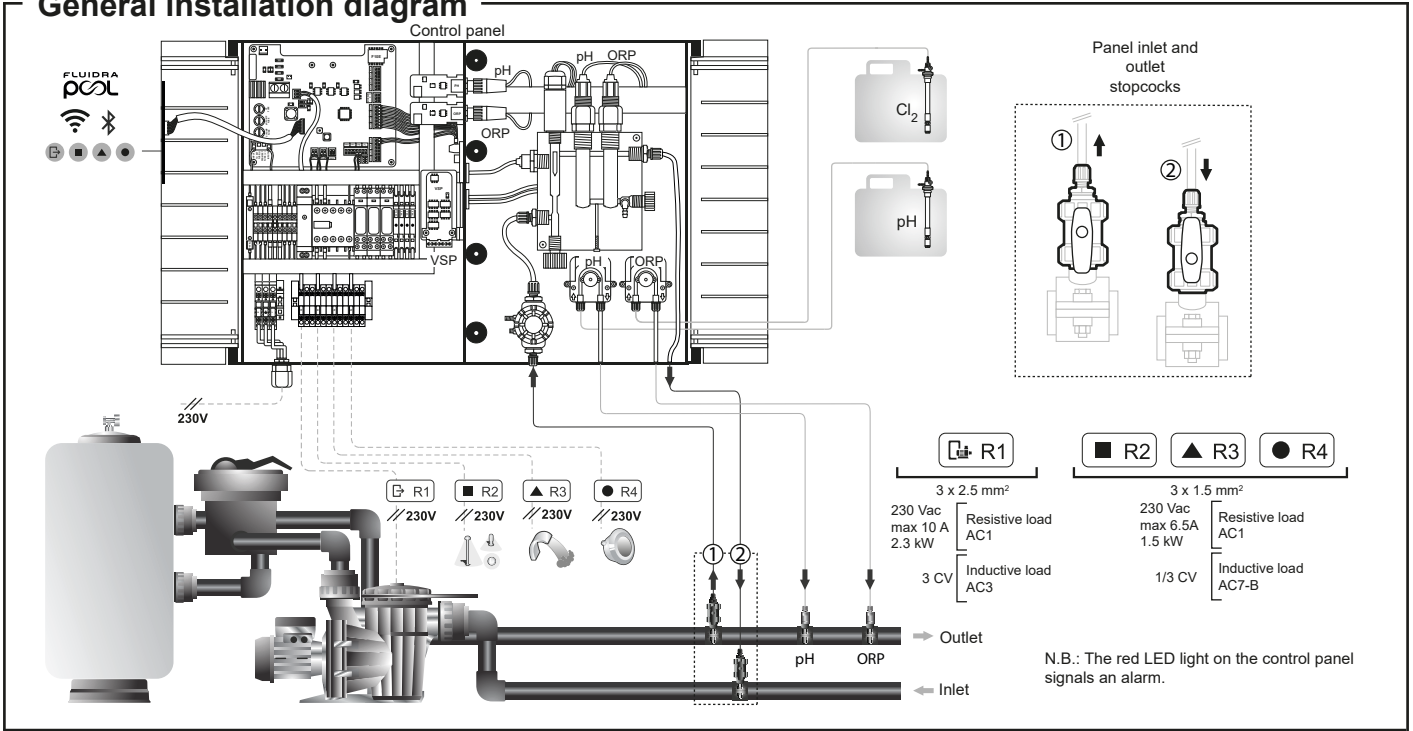

Main screen and functions

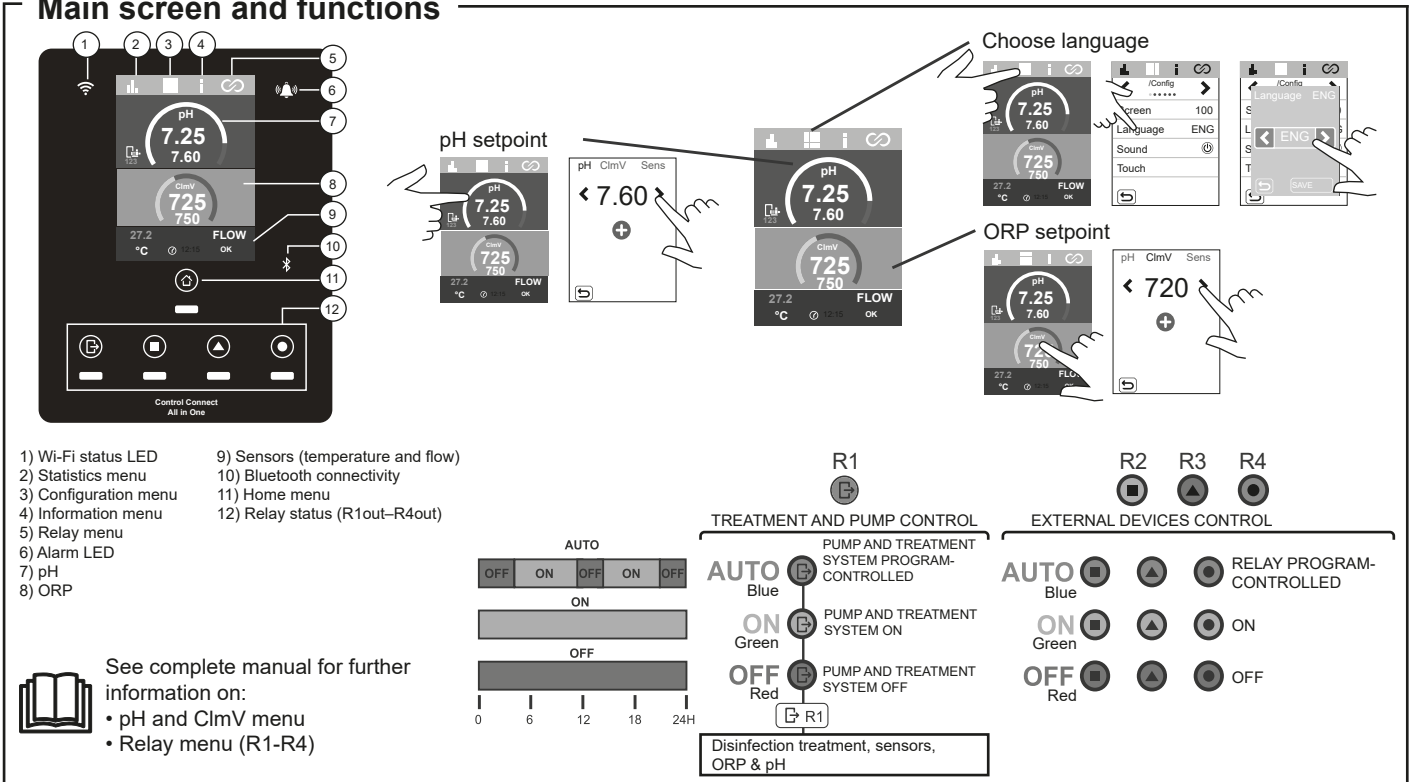

Initial Start-Up

1. Make sure that the filter is clean and that there is no copper or iron in the water in the pool or the installation.
2. Balance the pool water. This will enable more efficient treatment with a lower concentration of free chlorine in the water and reduce the build-up of limescale in the pool.
3. If the pool is to be used immediately, chlorine treatment should be carried out. Initial dose: 2 mg/L trichloroisocyanuric acid.

Pool water balance

The water must be maintained within the following parameters:

- Total alkalinity between 60 and 120 mg/L (ppm)
 - pH between 7.2 and 7.6
 - Free chlorine between 0.5 and 2 mg/L (ppm)
 - Chlorine stabiliser between 25 and 30 mg/L (ppm).
- In pools that are exposed to strong sunshine or intensively used, it is advisable to maintain a level of 25–30 mg/L of stabiliser (isocyanuric acid).

Check and maintain correct water balance throughout the season.



See complete manual for further information on:

- Installation and calibration of pH, ORP and temperature sensors
- Maintenance of peristaltic pumps

User interface / functions

PAIRING WITH FLUIDRA POOL

1) Download and install the FLUIDRA POOL app



2) Create a user account and set up the pool parameters



3) Activate pairing mode on the equipment



By pressing home menu for 5 sec

4) Press Add Equipment and follow the FLUIDRA POOL instructions

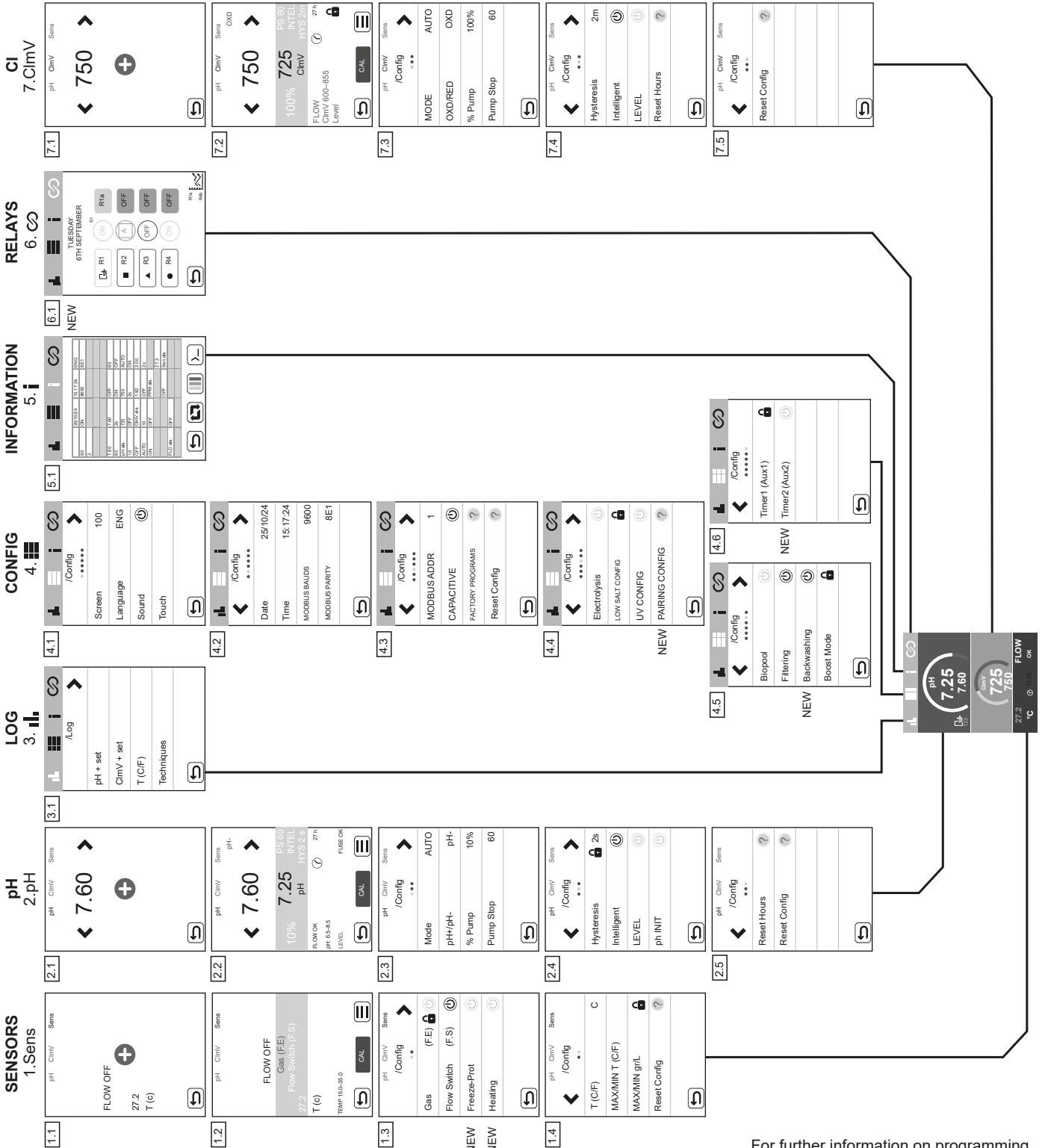
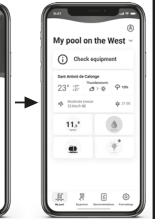
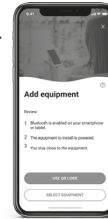

ON OFF



For further information on programming and configuring the following menus, see complete manual:

- Sensors, Configuration and Relays
- New functions: Freeze Protection, Heating, Pairing, Backwashing

Basic troubleshooting



See complete manual for information on:
 • Configuring the alarms

| Message | Solution |
|--|---|
| Inductive FLOW alarm (FS) | The flow alarm will appear if there is no water flow (inductive flow sensor). - Check the pump, filter and backwash valve. Clean if necessary. - Check the flow sensor wiring connections. |
| ORP(mV) – High/low alarm | Low or high alarms appear if the reading is not within established safety limits. High and low ClmV safety limits cannot be changed. Standard mode: ClmV > 855 = HIGH ORP ALARM Biopool mode: ClmV > 855 = HIGH ORP ALARM Check the level of chlorine in the pool using a photometer or a test strip. If necessary, clean and calibrate the ORP sensor. If the free chlorine value is low and the total chlorine value is high, reduce the chloramines by superchlorinating with sodium hypochlorite. If the deviation is high during the calibration process, the equipment will report an error and the probe must be replaced. Standard mode: ClmV < 600 = LOW ORP ALARM Biopool mode: ClmV < 300 = LOW ORP ALARM Check the level of chlorine in the pool using a photometer or a test strip. If necessary, clean and calibrate the ORP sensor. If chlorine ppm are high and the mV reading is low, check cyanuric acid concentration. Should the values be above 60 ppm, partially drain the pool. Increase daily filtering. If the deviation is high during the calibration process, the equipment will report an error and the probe must be replaced. |
| pH Low/High alarm | Low or high alarms appear if the reading is not within established safety limits. These safety limits cannot be changed. If the high pH alarm appears, the pH pump will be switched off for safety reasons. Standard mode: pH > 8.5 = pH HIGH ALARM = Pump off Biopool mode: pH > 9.0 = pH HIGH ALARM = Pump off Check the pH of the pool water using a photometer or a test strip. If necessary, clean and calibrate the pH sensor. If the deviation is high during the calibration process, the equipment will report an error and the probe must be replaced. The pH of the pool must be manually reduced to 8.45 (standard mode) or 8.95 (biopool mode) for the pump to start dosing again. Standard mode: pH < 6.5 = LOW pH ALARM Biopool mode: pH < 6.0 = LOW pH ALARM Check the pH of the pool water using a photometer or a test strip. If necessary, clean and calibrate the pH sensor. If the deviation is high during the calibration process, the equipment will report an error and the probe must be replaced. |
| Low/High Temperature Sensor Alarm | - The temperature alarm will appear when the temperature values set by the user (1.Sens/1.4 Max.-Min. T(C/F)) are out of the programmed range. |
| PUMP-STOP alarm | When the P.STOP FUNCTION for pH and ORP is activated (default 60 min), the system stops the dosing pump after a programmed time without having reached the pH and ORP set point, triggering the PUMP-STOP alarm. - Check the pool's pH and ORP values using a photometer or a test strip. - If necessary, clean and calibrate the pH and ORP sensors. - Check and adjust the alkalinity of the water (consult your pool specialist). - Check the levels of acid in the container. To restore the Pump-Stop function, reset the alarm in the relevant menu: - 2.2 P.STOP-alarm / RESET P.STOP. The pump will restart if the pH value is above the set point and below 9.0. - 7.2 P.STOP-alarm / RESET P.STOP. The pump will restart if the ORP value is below the set point. <div style="text-align: center;"> <p>Reset the PUMP-STOP alarm.</p> </div> |
| Level Alarm | The level alarm appears when there is no chemical product left in the containers. - Check the level of the chemical dosing containers. If empty, refill accordingly. - Verify that the float on the level sensor is positioned correctly. The black mark should be at the bottom of the float. <div style="text-align: right;"> </div> |

PLEASE NOTE: This instruction manual contains essential information about the safety measures to adopt during the installation and commissioning. Hence, it is essential, that both the installer and the user read these instructions before installing and using the equipment.

Keep this manual for future reference about operating this device.

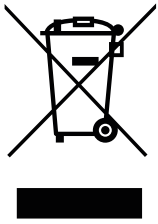

Treatment of electrical and electronic devices at the end of their useful life (applicable in the EU only)

Products marked with this symbol cannot be thrown out with domestic rubbish when they reach the end of their useful life. The user is responsible for depositing this type of refuse in a recycling point for electrical and electronic waste. Proper treatment and recycling of this waste makes an essential contribution to the conservation of the environment and users' health. For more precise information on the collection points for this type of waste, contact your local authorities.

The instructions in this manual describe the control panel operation and maintenance for **76752 CONTROL CONNECT ALL IN ONE**. To obtain the best performance from the equipment, please follow the instructions below:

1. General Information

1.1 General Characteristics

Once the control panel has been installed, the pool water must be balanced as follows:

- Its pH should be 7.2–7.6.
 - Total alkalinity should be 60–120 ppm.
 - Level of chlorine in the water should be 0.5–2 ppm.
- The control panel is in two sections. The one on the left contains the electrical installation, while the right-hand section contains the sensors and control components.
 - Maintaining a certain level of chlorine in the pool water guarantees its quality.
 - The control panel will dose chlorine when the pool's recirculation system (pump and filter) are running.
 - The equipment has several safety devices which are activated in the event of a system malfunction, as well as a control micro-controller.
 - The control panel includes automatic pH and ORP controllers.

⚠ 1.2 Safety Warnings and Recommendations

- Installation and manipulation should only be performed by suitably qualified technicians.
- Applicable standards for prevention of accidents and for electrical installations must be respected. During installation, bear in mind that electrically disconnecting the equipment requires a switch or circuit breaker according to standards IEC 60947-1 and IEC 60947-3 which ensures an omnipolar cut-off, directly connected to the power supply terminals and with a contact separation in all poles, providing total disconnection under overvoltage category III conditions, in an area that fulfils the safety requirements of the site. The switch must be located in the immediate vicinity of the equipment and must be easily accessible. Additionally, it must be marked as the equipment's disconnection element.
- The equipment must be fed from a residual current device (RCD) not exceeding 30mA. The equipment must be earthed.
- The installation must comply with the requirements of IEC / HD 60364-7-702 and national standards applicable to swimming pools.
- The manufacturer accepts no responsibility for assembly, installation or setting up, nor for any manipulation or addition of components other than when carried out at the manufacturer's premises.
- This appliance is not intended for use by persons (including children) with reduced physical, sensory or mental capabilities, or who lack experience or knowledge, unless they have been given supervision or instruction concerning use of the appliance by a person responsible for their safety. Children should be supervised to ensure that they do not play with the appliance.
- The control unit operates at 230 Vac / 50 Hz. Do not attempt to alter the power supply to operate at any other voltage.
- Ensure that all electrical connectors are properly tightened, to avoid bad connections leading to overheating.
- **⚠** Before installing or replacing any system component, ensure that the system has been disconnected from the power supply and that no water is flowing through it. Only use genuine replacement parts.
- Since the equipment generates heat, it is important to install it in a sufficiently ventilated place and to keep the ventilation openings free of any obstructions. Do not install near flammable materials.
- The control panel has an IP45 rating. Never install it in areas at risk of flooding.
- This equipment must be permanently connected to the water supply and should not be connected using a temporary supply.
- This device is equipped with a mounting bracket; see installation instructions.

Keep this Instruction Manual for future reference.



Please read the instruction manual before continuing to install the equipment.

1.3 Contents

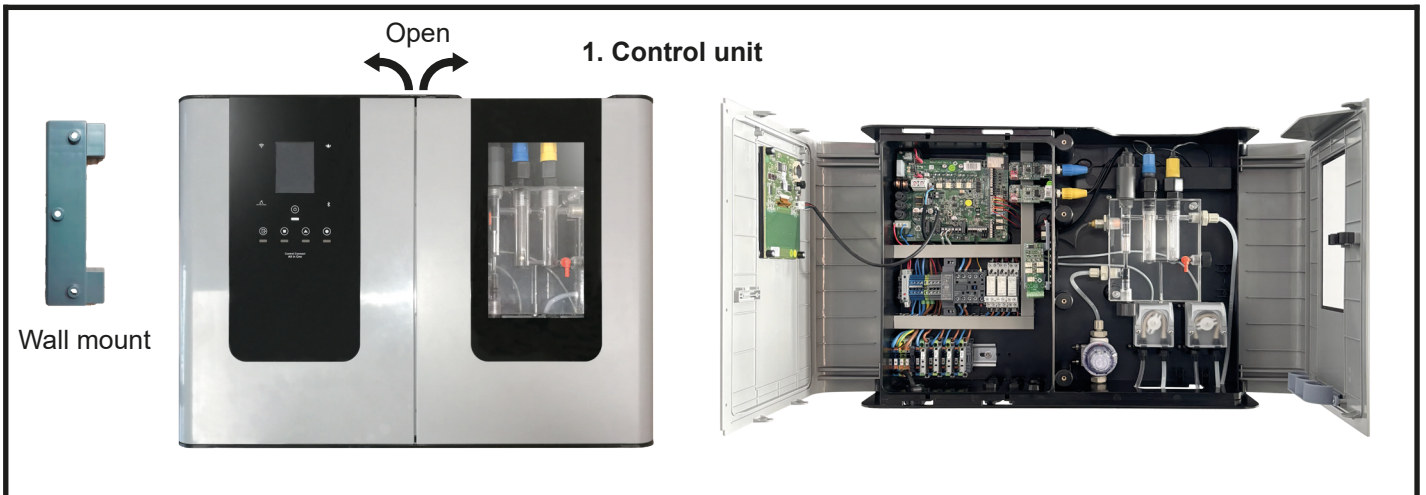

2. pH kit



3. ORP kit



4. Panel Inlet and Outlet Connections (x2)



5. Injection points (x2)



Contents:

1) Control unit and wall mount

2) PH kit

- pH sensor
- Calibration solutions pH7 and pH4
- Suction filter for pH container
- Flexible tubing (PVC6X4) (clear)

3) ORP kit

- ORP sensor
- Calibration solution 470 mV
- Suction filter for Cl₂ container
- Flexible tubing (PVC6X4) (clear)

4) Panel inlet and outlet connections (2 of each):

- Rigid tubing (PE6X4)(white)
- 1/2" to T6/4 adapter
- Inlet and outlet valves
- 1/2" PVC male threaded adapter socket
- O-ring
- Sleeve

5) Injection points (2 of each):

- Rigid tubing (PE6X4)(white)
- Injector and o-ring
- Adapter G1/2" - G3/8" and o-ring
- Sleeve

Optional accessory

VSP driver kit



SKU 77420

6) Level sensor and suction kit (x2)



SKU 77584

1.4 Specifications



| Description | |
|---------------------------------------|--|
| Operating voltage | 230 V ac 50 Hz |
| Consumption (W) | 27 W |
| Parameters | pH, ORP, T(°C) |
| Control outputs | R1 (pump): 230 V ac, 10A max, 2.3 kW R2, R3, R4 (aux): 230 V ac, 6.5A max, 1.5 kW |
| Control inputs | 4 potential-free (interlocks) |
| Operating range | 6.50 - 8.50 (pH) / 600 - 855 mV (ORP) |
| Operating range Biopool ON | 6.00 - 9.00 (pH) / 300 - 855 mV (ORP) |
| Inductive flow sensor | Yes |
| System interface | Colour LCD touchscreen |
| Remote control (cable) | 4 digital – 4 relay |
| Data acquisition | pH, ORP, temperature (24 days) |
| Housing | ABS |
| Modbus & Fluidra Pool (compatible) | Yes |
| Probe holder material | Methacrylate derivative |
| Connection to piping | PVC-U, PN 16 valves PE6X4 pipe |
| Maximum pressure | 1 kg/cm ² |
| Operating temperature | 15–40 °C max |



| pH, ORP and temperature sensors | |
|---------------------------------|--|
| Measurement range | 0.00 - 9.99 (pH) / 000 - 999 mV (ORP) / 0-50°C (Temperature) |
| Set point range | 7.00 - 7.80 (pH) / 600 - 850 mV (ORP) |
| Set point range Biopool ON | 6.50 - 8.50 (pH) / 300 - 850 mV (ORP) |
| Accuracy | ± 0.01 (pH) / ± 1 mV (ORP) / ± 0.1°C (Temperature) |
| Calibration | Automatic (pH-ORP solutions) |
| pH and ORP sensors | Glass body, single joint |



| VSP driver (SKU 77420) (optional) | |
|-----------------------------------|---|
| | Variable speed pump control, up to three speeds |
| | Automatic pneumatic-hydraulic valve control |
| | Automatic filter backwashing |
| | Hourly programming at various filtering rates |

1.5 Dimensions

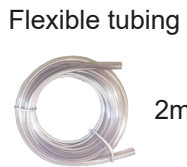
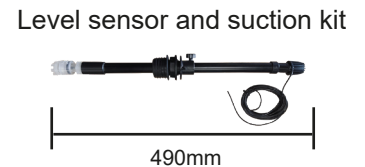
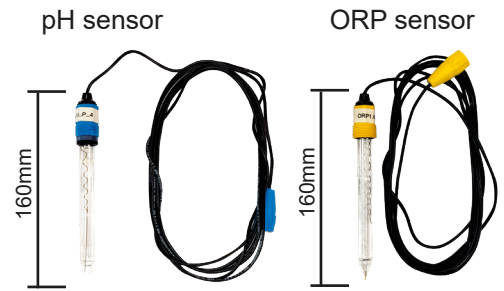
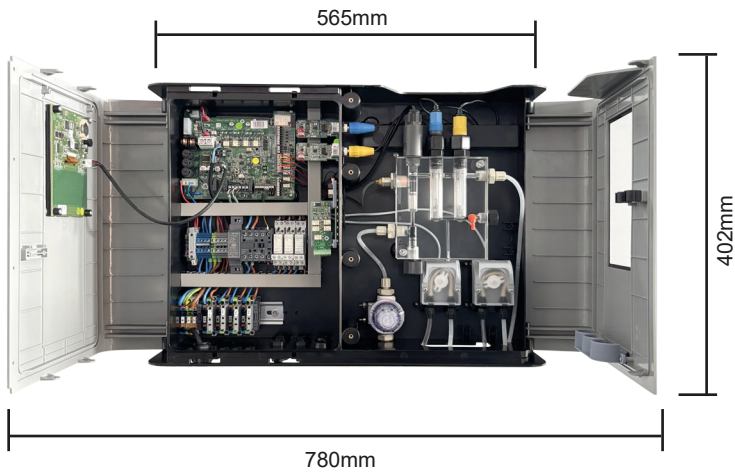

Optional accessory

VSP driver kit

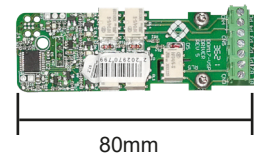

2. Control Panel Installation

2.1 Wall Mounting

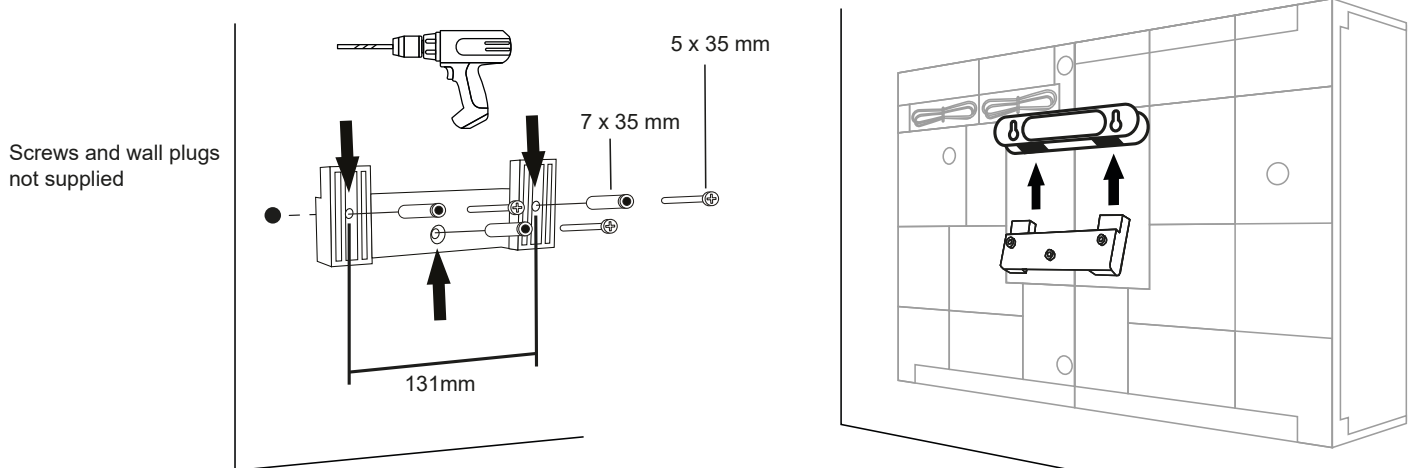

Always install the control panel VERTICALLY and on a rigid surface (wall), as shown in the recommended installation diagram. To ensure that the equipment remains in good condition, it should always be installed in a dry, well-ventilated location. The equipment must not be installed outdoors.

It is important to avoid the formation of corrosive atmospheres due to pH reducers (specifically, those based on hydrochloric acid, "HCl"). Do not install the system close to areas where these products are stored. We strongly recommend that products based on sodium bisulphate or dilute sulphuric acid be used. The control unit must be connected to the mains in the control panel of the filter system, such that the pump and the system are connected simultaneously.

2.2 Access to Panel Sections

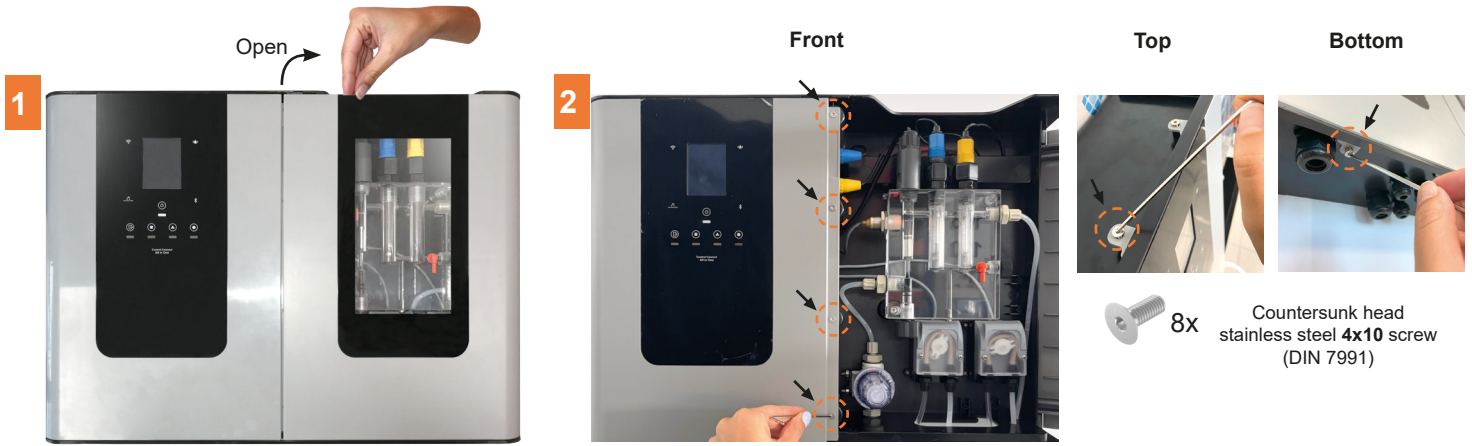

To access the sensor and control components section, open the panel by pulling the top edge of the right-hand door.

To access the electrical connections section, open the left-hand door of the panel by unscrewing the 4 front, 2 top and 2 bottom screws using a 2.5 Allen key.

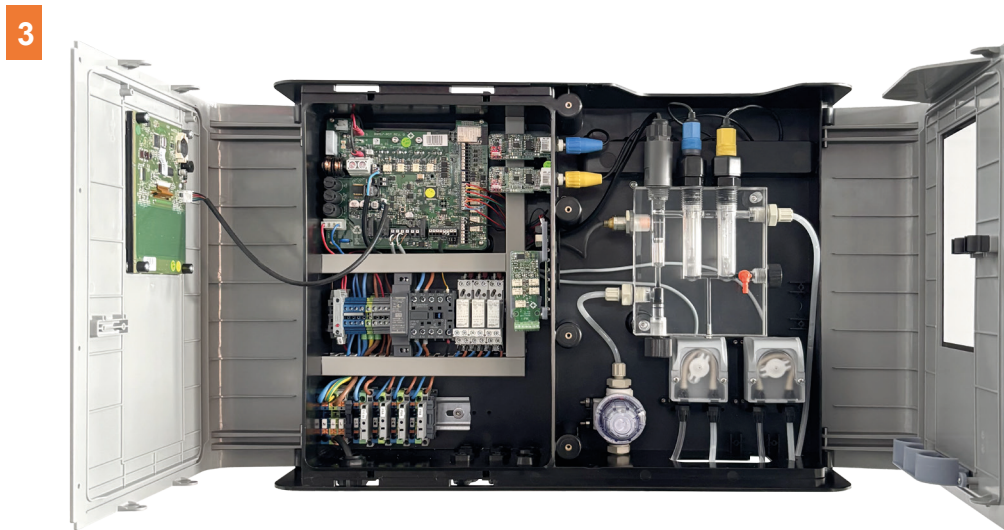

The installation should allow easy user access to the various elements of the panel.

Caution

Closing the equipment

To close the equipment, reinsert the screws on the front left-hand-side of the panel, placing them in their housings in sequential order from position 1 to position 4. Next, tighten the screws in the same sequence. Finish by fastening the screws at the top and bottom of the panel.

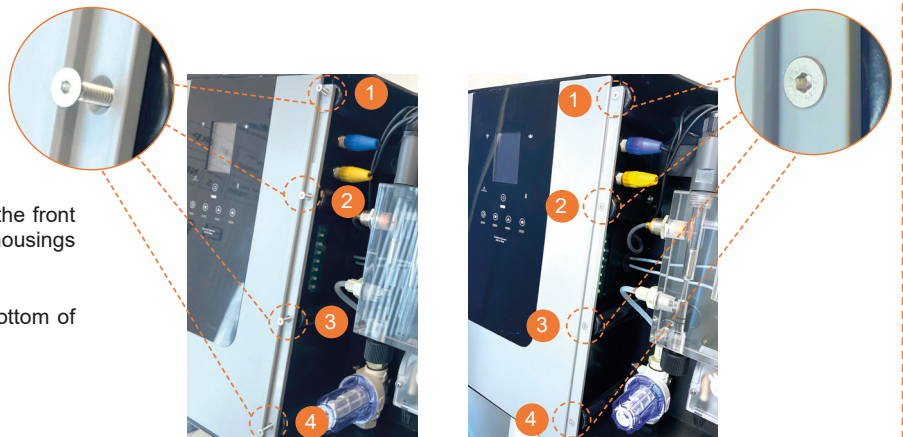

2.3 General Hydraulic Installation Diagram



Caution: The panel inlet and outlet must be connected to the corresponding inlet and outlet valves. Make sure the valves are fitted in the correct orientation, as shown on the recommended installation diagram. **For details, see sections 4.1 to 4.3.**

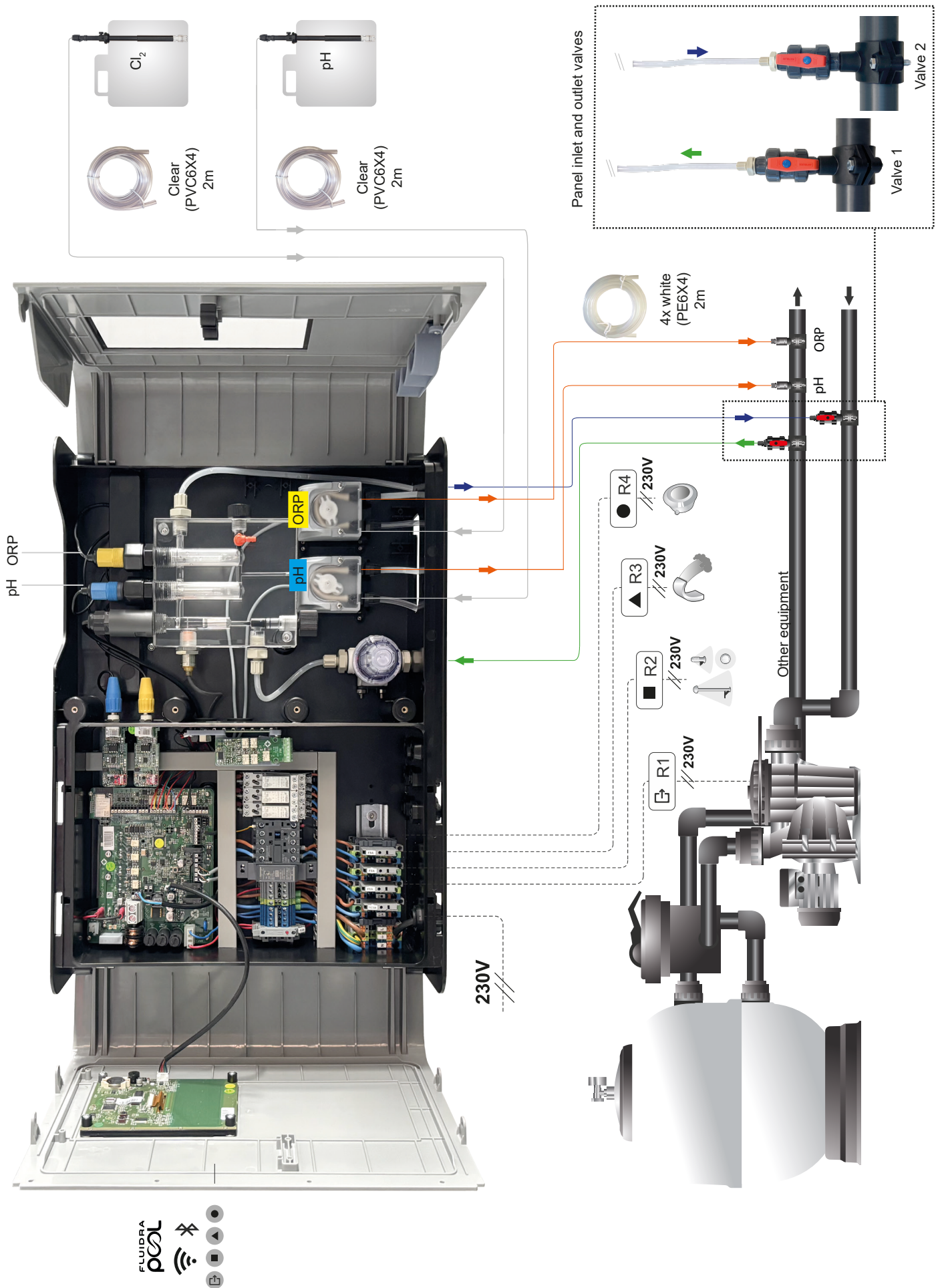

3. Panel Sections and Connections

A. Electronic board and VSP driver (optional accessory)

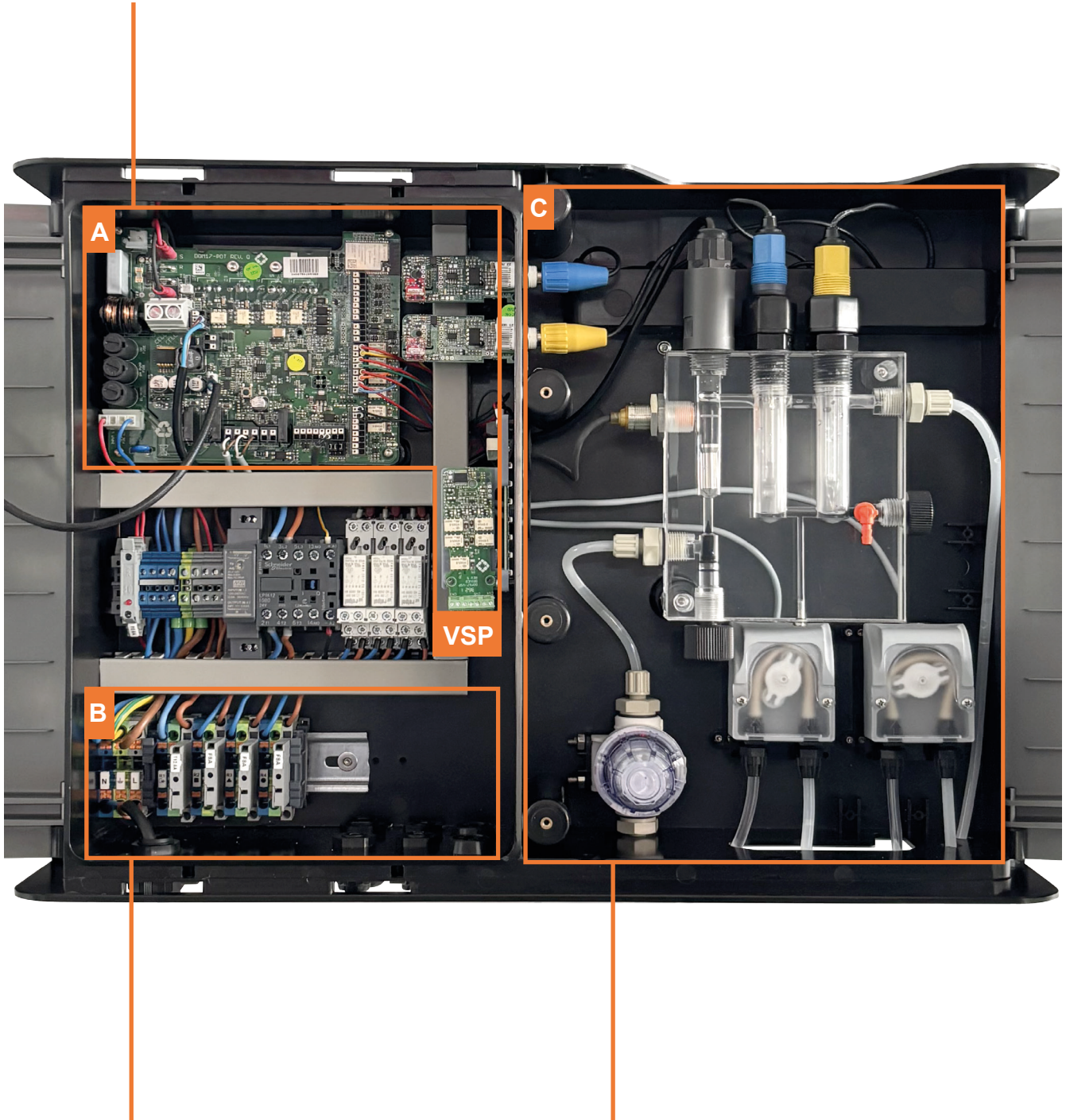

B. Electrical Connections – 230 Vac and R1–R4

C. Sensors and control

3.1 Electronic Board

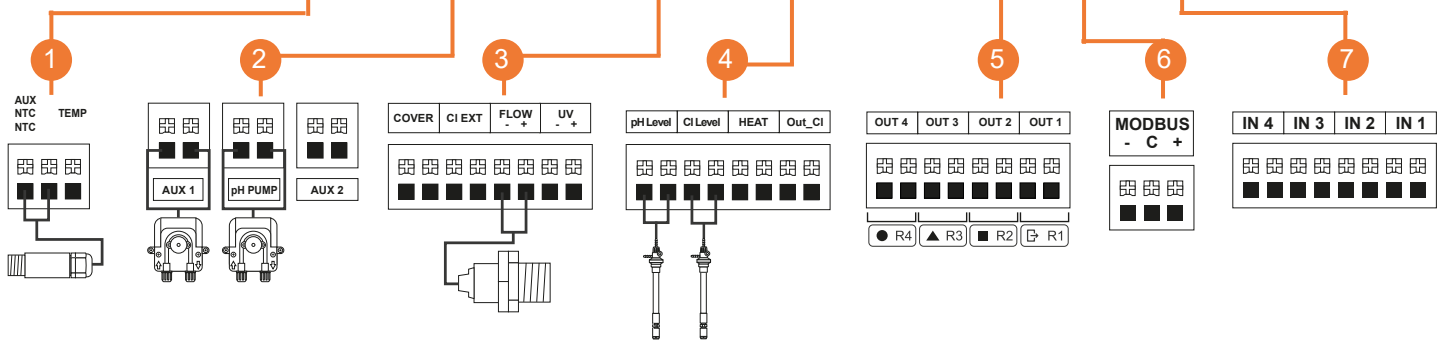
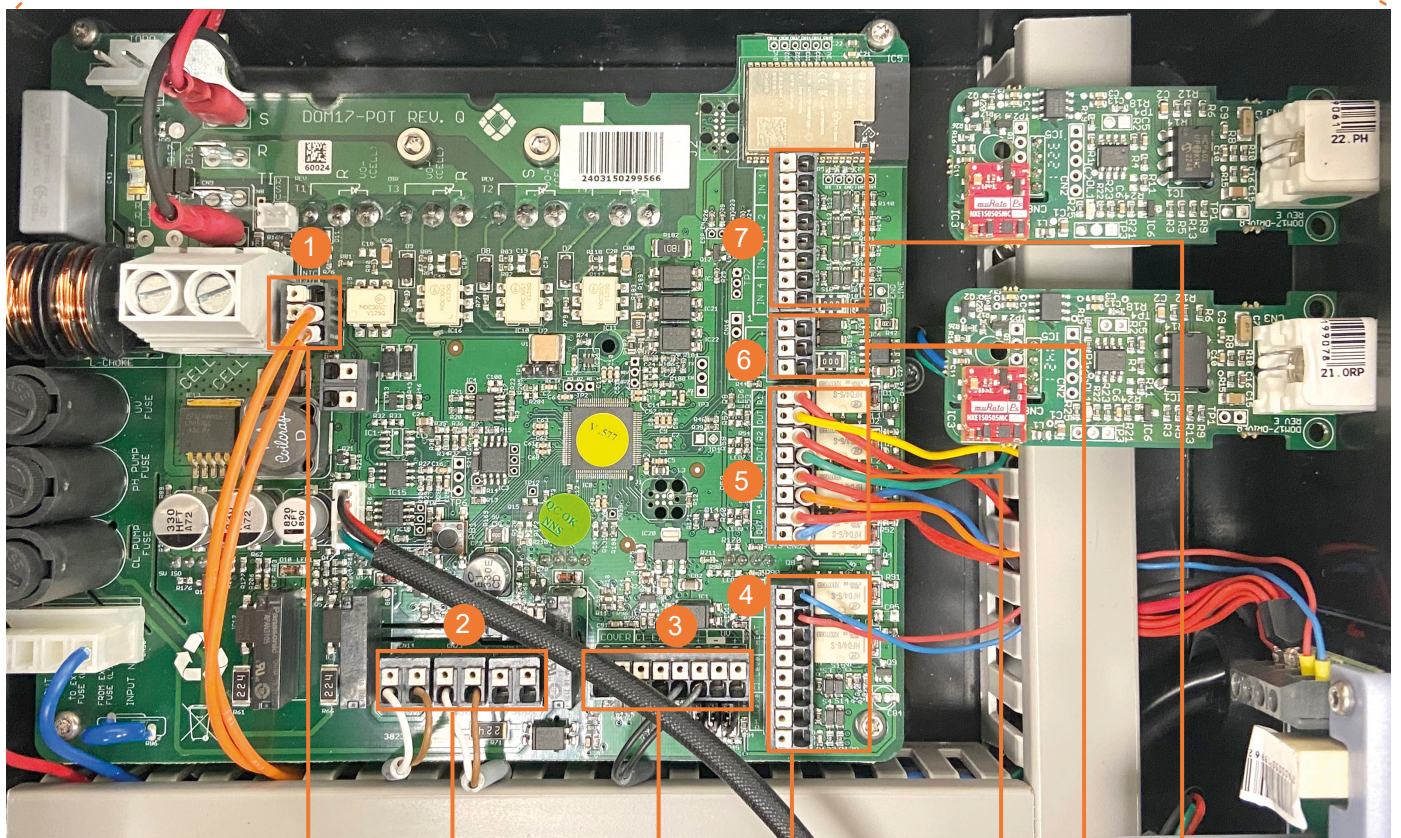
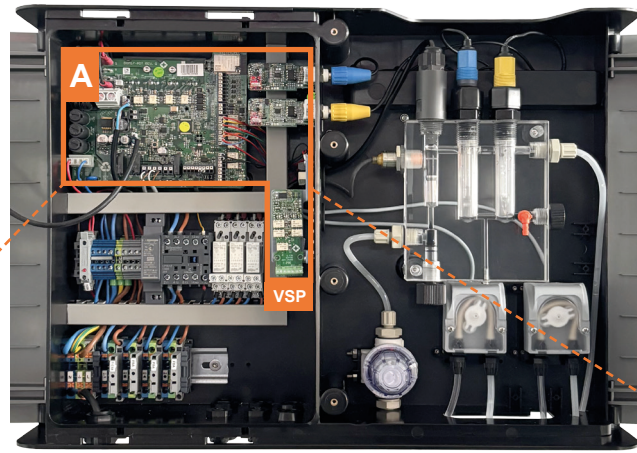

3.2 Electrical Connections – 230 Vac and R1–R4 Outputs (Configuration 1 and 2)



ATTENTION: Before making the electrical connection of the relays, check which configuration your equipment has: **Configuration 1** or **Configuration 2**.

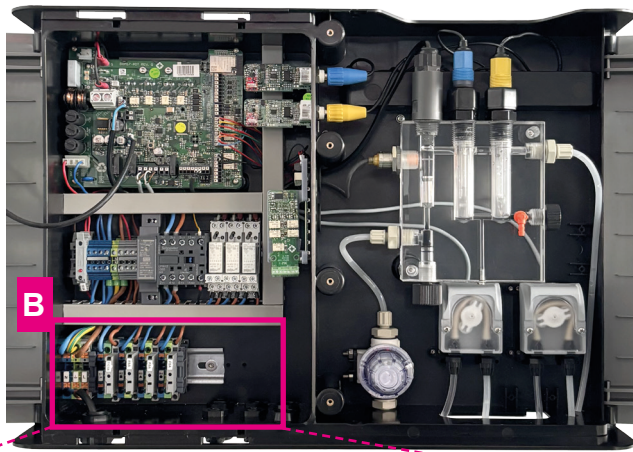

Configuration 1

N L L

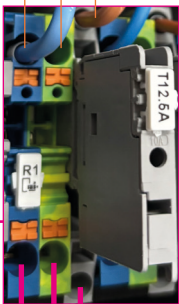

Push in Tension clamp

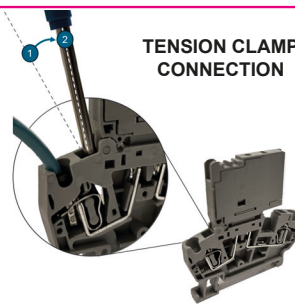
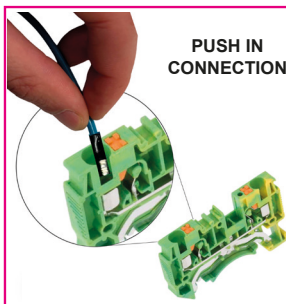

Connections:
VSP kit (optional)(SKU 77420),
suction kit and level sensor
(SKU 77584)

The equipment has two cable feedthroughs at the bottom of the panel for connecting optional accessories.

To be used, these must be performed using a 3 x 0.5 mm screwdriver and then the connecting cables passed through them.

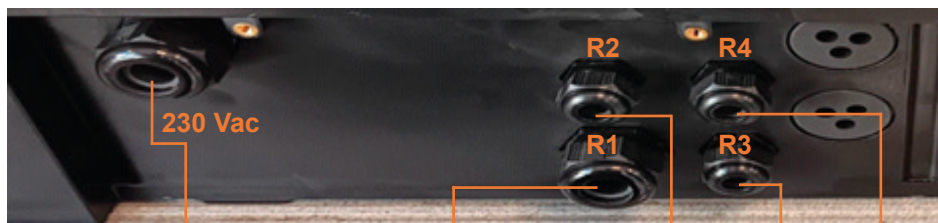
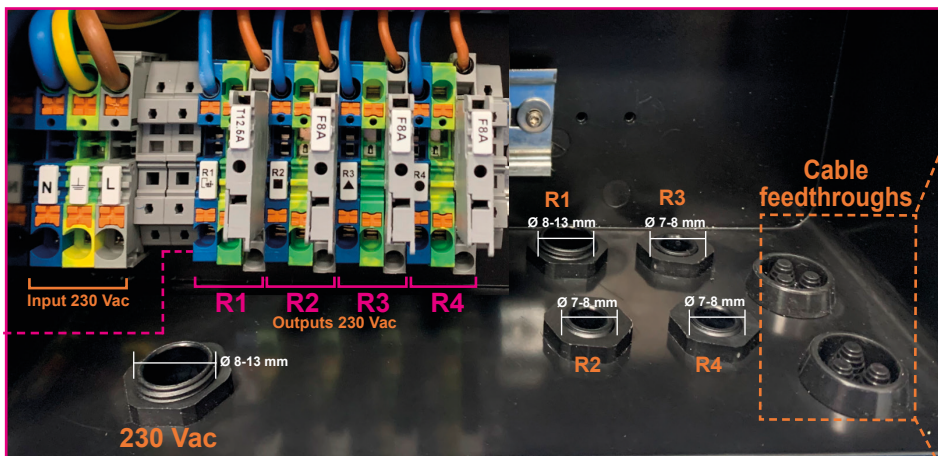
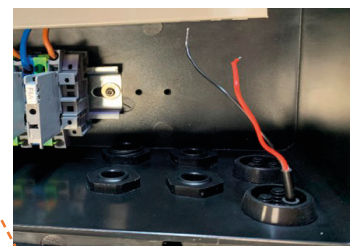
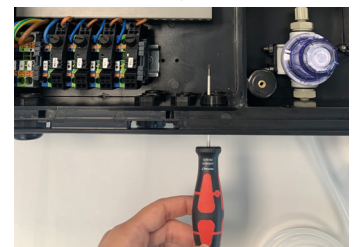
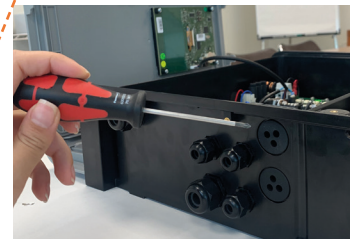

Maximum charge
Recommended cable 3 x 6 mm²

230 Vac
max 30A
6.9 kW



R1
3 x 2.5 mm²

230 Vac
max 10A
2.3 kW

3 CV Inductive
load AC3



R2 R3 R4
3 x 1.5 mm²

230 Vac
max 6.5A
1.5 kW

1/3 CV Inductive
load AC7-B

3.2 Electrical Connections – 230 Vac and R1–R4 Outputs (Configuration 1 and 2)



ATTENTION: Before making the electrical connection of the relays, check which configuration your equipment has: **Configuration 1** or **Configuration 2**.

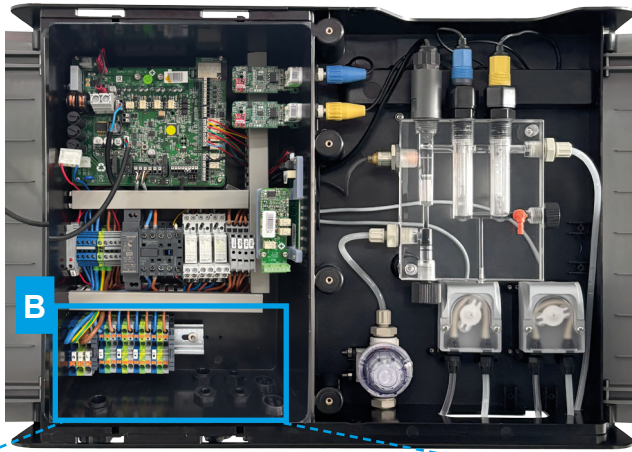

Configuration 2

N L



Push in

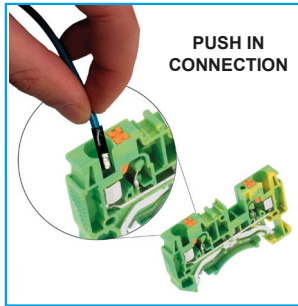

Connections:
VSP kit (optional)(SKU 77420),
suction kit and level sensor
(SKU 77584)

The equipment has two cable feedthroughs at the bottom of the panel for connecting optional accessories.

To be used, these must be performed using a 3 x 0.5 mm screwdriver and then the connecting cables passed through them.

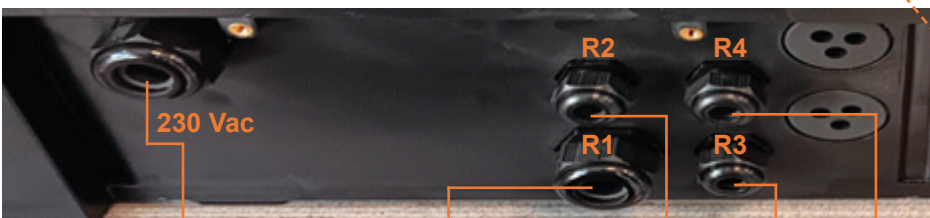
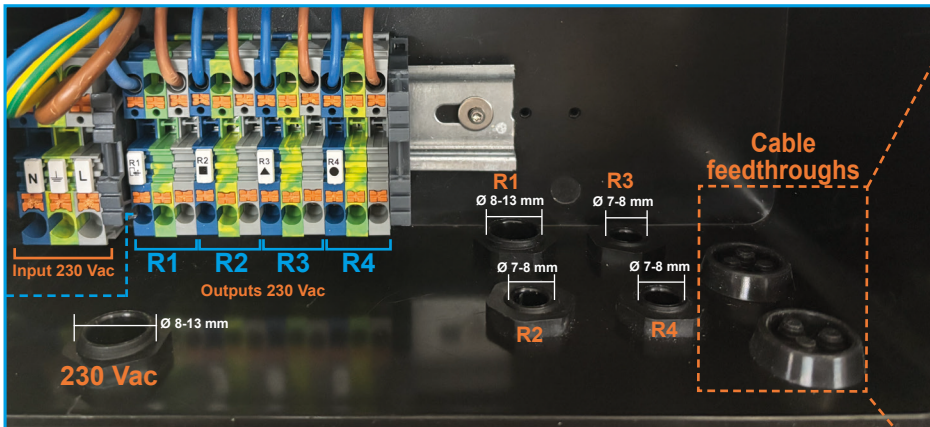
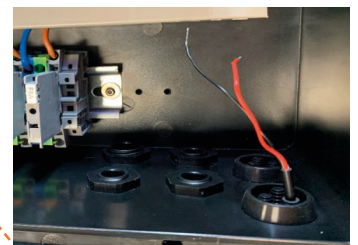
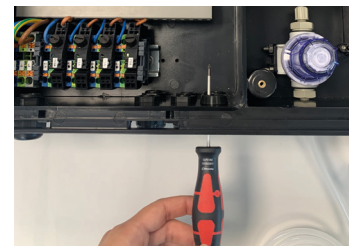
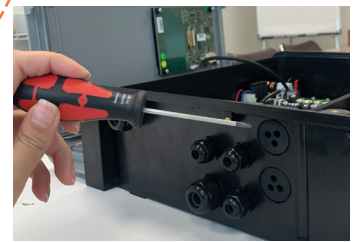

Maximum charge
 Recommended cable 3 x 6 mm²

230 Vac
 max 30A
 6.9 kW

R1
 3 x 2.5 mm²

230 Vac
 max 10A
 2.3 kW

3 CV Inductive load AC3

R2 R3 R4
 3 x 1.5 mm²

230 Vac
 max 6.5A
 1.5 kW

1/3 CV Inductive load AC7-B

3.3 Sensors and Control Components

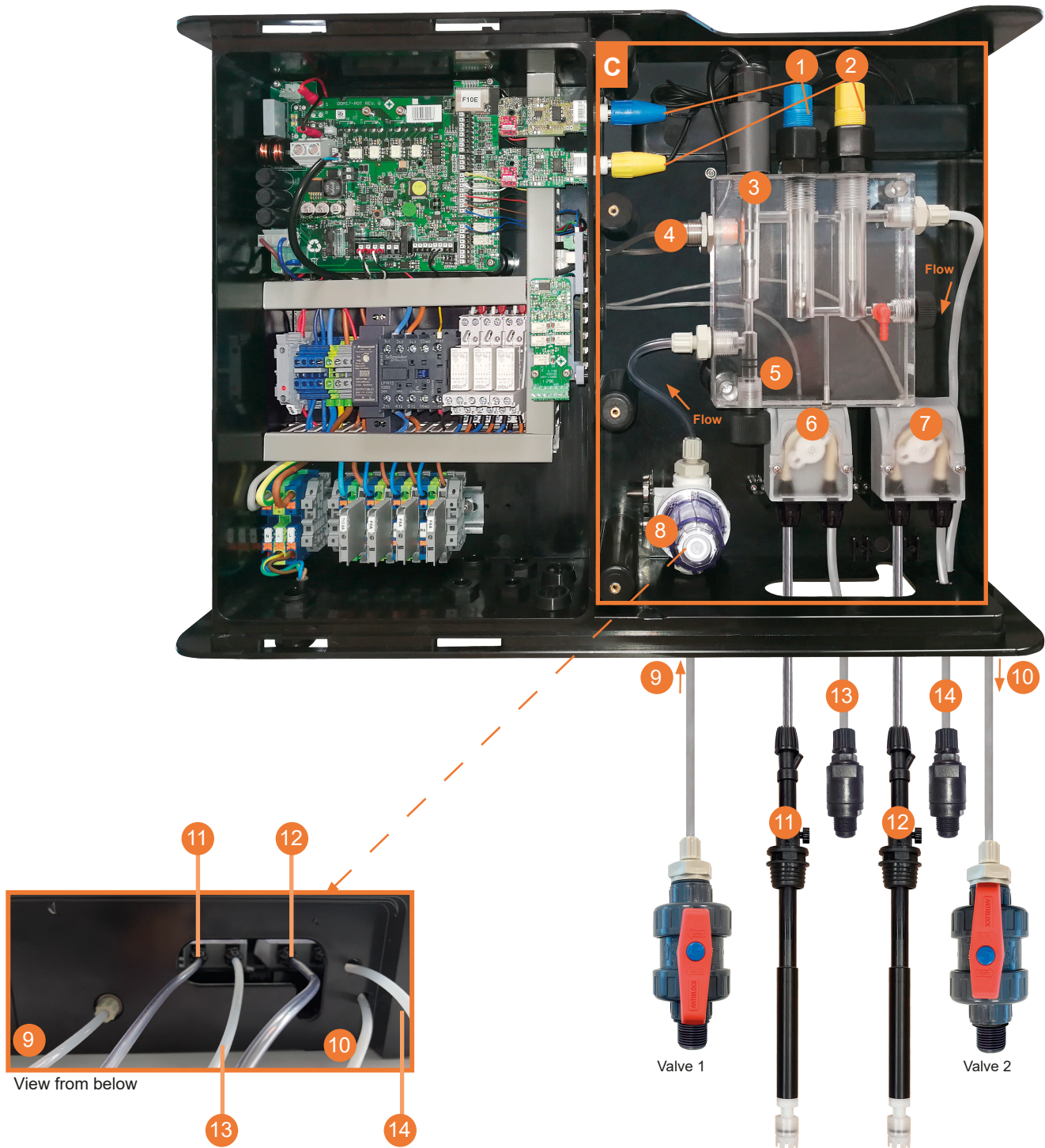

- 1) pH sensor
- 2) ORP sensor
- 3) Temperature sensor
- 4) Inductive flow sensor
- 5) Flow control
- 6) pH peristaltic pump
- 7) Cl₂ peristaltic pump
- 8) Panel pre-filter
- 9) Inlet connection: white tubing (PE6X4) and valve 1
- 10) Outlet connection: white tubing (PE6X4) and valve 2
- 11) pH suction: clear tubing (PVC6X4) and level sensor
- 12) Cl₂ suction: clear tubing (PVC6X4) and level sensor
- 13) pH injection point: white tubing (PE6X4) and injector
- 14) Cl₂ injection point: white tubing (PE6X4) and injector

4. Initial Start-up and Installation of Components

4.1 Control Panel Inlet and Outlet Valve General Installation Diagram

For water to circulate through the panel, the sleeves must be connected with the inlet and outlet valves (**valve 1** ↑ and **valve 2** ↓, respectively) to the equipment in the pool's water tubing, as shown on the diagram.

Valve 1: This valve is located at the supply point, where the water enters the panel, passes through the pre-filter and then enters the probe holder to be measured and then controlled.

Valve 2: This valve is located at the panel's suction point and water outlet.

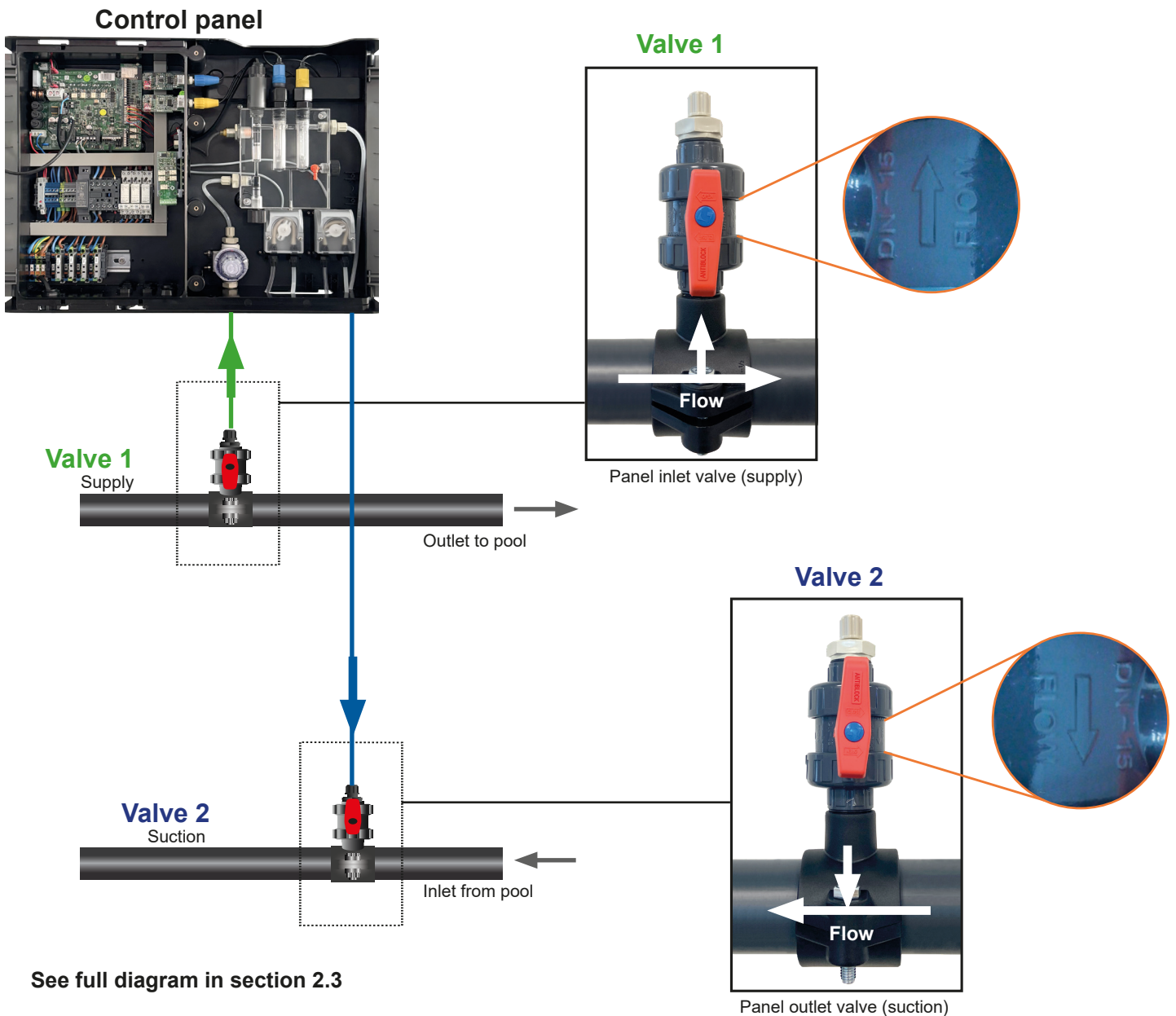

See full diagram in section 2.3



Caution

The FLOW arrow on the valve indicates the direction of flow.

Correct valve orientation **MUST** be checked for the panel's inlet (**valve 1** ↑) and outlet (**valve 2** ↓).

4.2 Panel Inlet and Outlet Connections

Inlet



1 Unscrew the connector from inlet union (pre-filter connection)

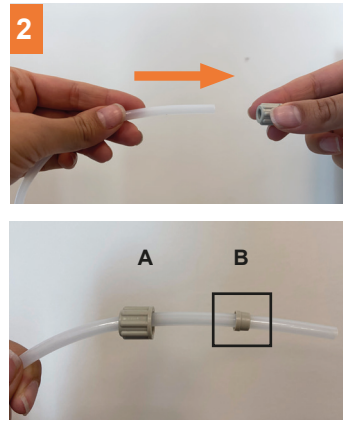

2 Fit the connector onto the rigid (white) tubing. **Make sure the orientation of the two parts is as shown in the photo. Part B (ferrule) is inside part A (connector).**

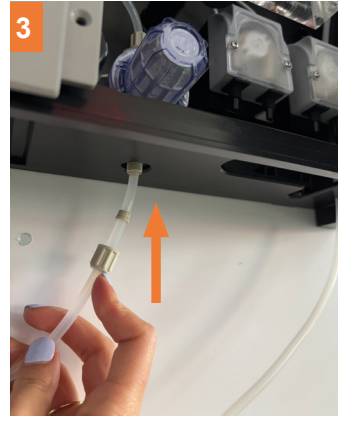

3 Push the rigid tubing into the inlet union



4 Screw on the connector and check that the tubing has been tightened correctly

Outlet



1 Unscrew the connector from the outlet union

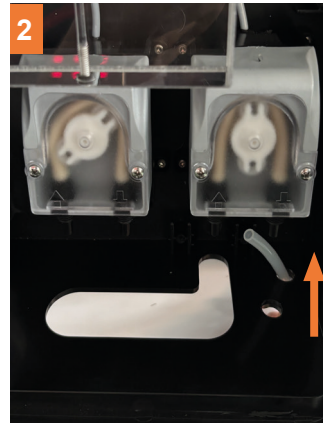

2 Introduce the rigid tubing into its allocated space at the bottom of the panel



3 Fit the connector and ferrule onto the rigid (white) tubing. **Make sure the orientation of the two parts is as shown in the photo. Part B (ferrule) is inside part A (connector).**

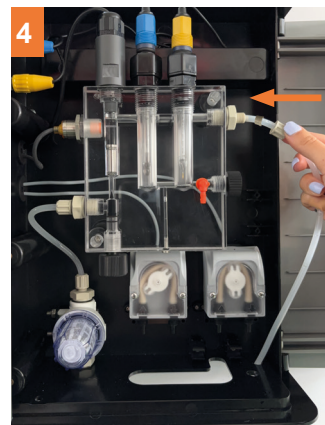

4 Push the rigid tubing into the outlet union

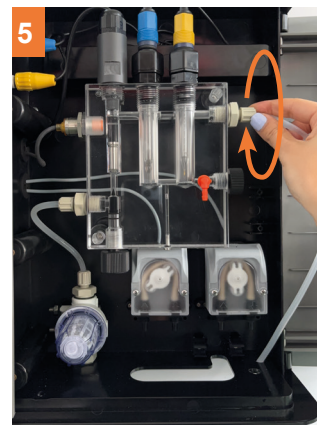

5 Screw on the connector and check that the tubing has been tightened correctly

4.3 Valve Installation



Caution

Follow these installation instructions for both the inlet and the outlet valve (**valve 1** ↑ and **valve 2** ↓, respectively).

Correct valve orientation **MUST** be checked, as shown on the installation diagram in **section 4.1**.

Valve components

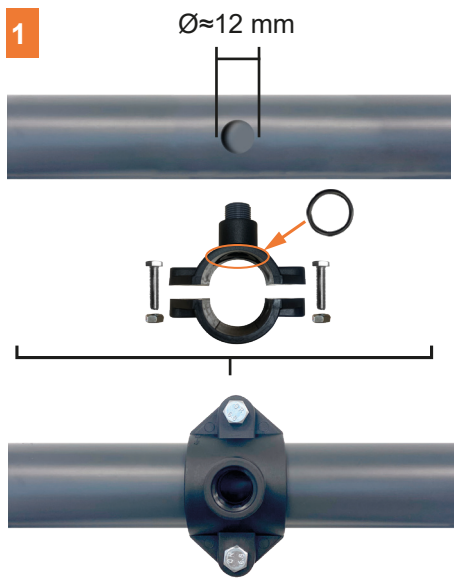
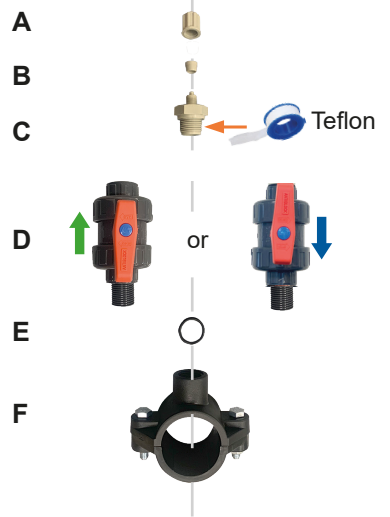

1 Perforate the pipe with a hole saw and clean the hole. Fit the sleeve, with the seal in its housing, over the hole in the pipe.



2 Screw the valve into the sleeve, following the order of components from F to D.



3 Approx. 8 turns of Teflon should be applied to the thread of part C before screwing it into valve D.

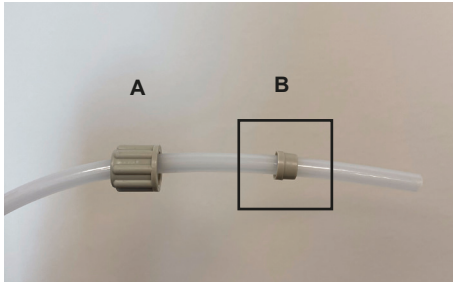
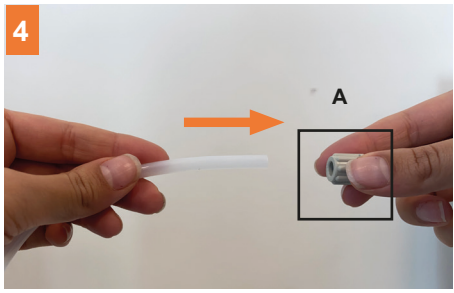

4 Fit the connector onto the rigid (white, PE6X4) tubing. **Make sure the orientation of the two parts is as shown in the photo. Part B (ferrule) is inside part A (connector).**



5 Push the rigid tubing into the valve adapter.



6 Screw in the connector and check that it has been tightened correctly.

4.4 pH and Cl₂ Peristaltic Pump Connection and Level Sensor Installation

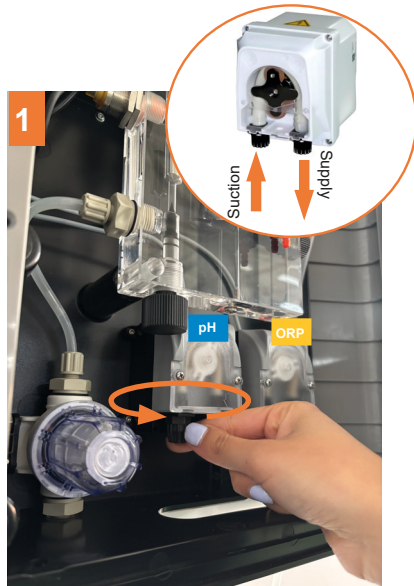

1 Unscrew the connector from the inlet (suction) of the pH peristaltic pump (left-hand pump)

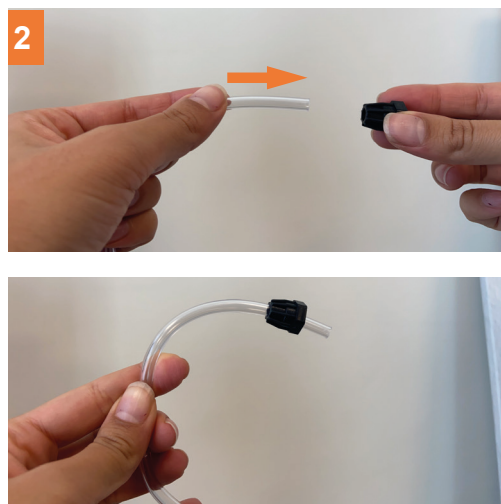

2 Push the connector onto the flexible tubing (clear, PVC6X4)

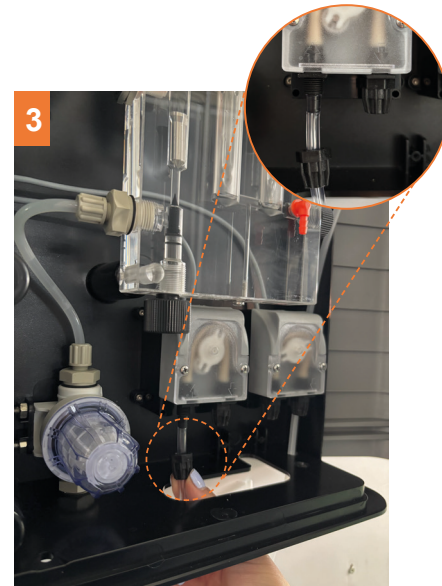

3 Push the flexible tubing into the pump's inlet union



4 Screw in the connector

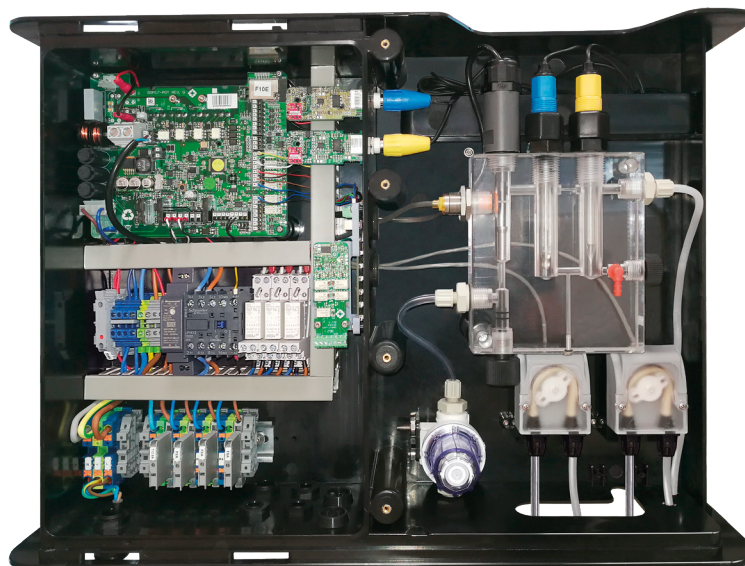

5 Repeat the above installation steps to connect the Cl₂ pump.



Caution: To avoid the risk of corrosion due to potential evaporation of the acid, do not place the containers right underneath the equipment.

Level Sensor Installation

Select the appropriate mounting option.

Option 1: Mounting with nut (Part C) (d = 34 mm)

Option 2: Mounting with rubber sleeve (Part D) (d = 40 mm)

If necessary, a hole can be drilled in the lid of the container.

1. Adjust the height by sliding the adjustment collar (Part B) according to the height of the container. Tighten the fixing screw (Part A) to secure it.

2. Follow the steps corresponding to the selected option:

Option 1 – With nut

- Insert the level sensor into the container.

- Tighten the nut from the inside of the container. If installed through the lid, tighten the nut from the inside of the lid and then screw the lid firmly onto the container.

Option 2 – With rubber sleeve

- First place Part D onto the sensor before inserting it into the container.

- Press gently downward until the sensor rests on the bottom of the container.

3. To connect the flexible tube, insert it by pressing firmly into the upper opening of the level sensor.

pH-Minus level sensor and suction

Cl₂ level sensor and suction

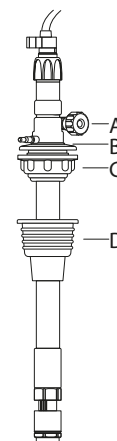

4.5 Injection Point Installation

Connection to peristaltic pumps

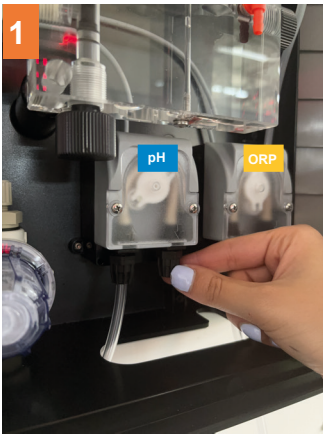

1 Unscrew the connector from the outlet (supply) of the pH peristaltic pump (left-hand pump)

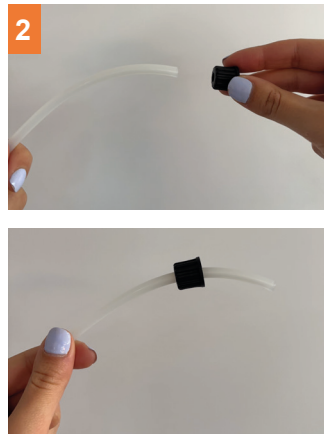

2 Fit the connector onto the rigid (white, PE6X4) tubing



3 Push the rigid tubing into the pump's outlet union



4 Screw in the connector

Connection to injection points

Injector components

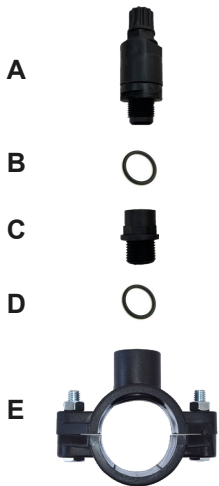

1 Place the o-ring on the adapter thread.



2 Screw the adapter into the sleeve.



3 Unscrew the connector from the injector.



4 Place the o-ring on the injector thread.



5 Screw the injector into the adapter previously placed on the sleeve.



6 Push the rigid tubing along with its connector into the injector.



7 Screw in the connector and check that it has been tightened correctly.

8 Repeat the above installation steps to connect the Cl_2 pump to its injection point.

4.6 pH and ORP Sensor Installation

On first installing the sensors, once connected to the equipment a standard calibration of both sensors must be carried out.
See sections 6.2 and 6.3.

Nut components

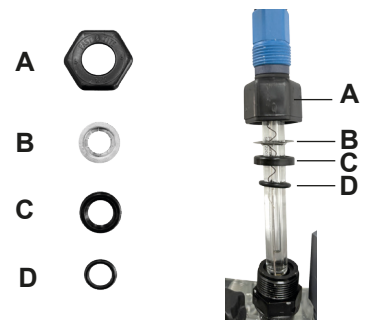

pH sensor



Unscrew the connector nut.



Insert the pH (blue) sensor into the housing on the left of the probe holder.

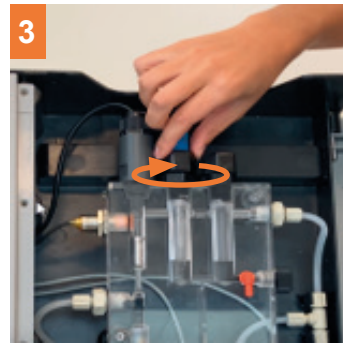

Screw the nut tightly onto the connector. Make sure the cable does not twist while screwing down the sensor.

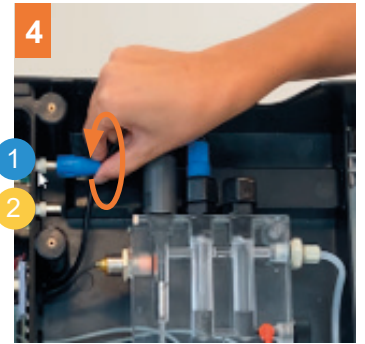

Connect the sensor to the pH driver (position 1)

ORP sensor



Unscrew the connector nut.

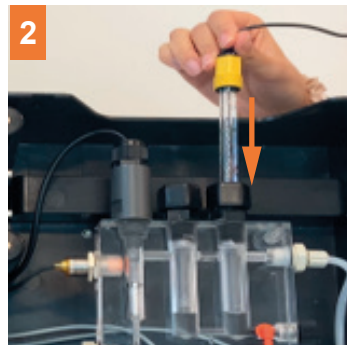

Insert the ORP (yellow) sensor into the housing on the right of the probe holder.

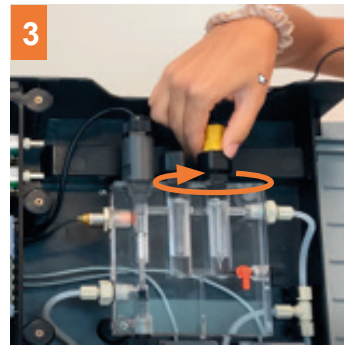

Screw the nut tightly onto the connector. Make sure the cable does not twist while screwing down the sensor.

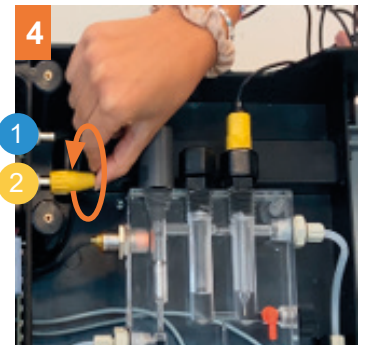

Connect the sensor to the ORP driver (position 2)



Caution

Once installed, check that the sensor is firmly held in place and cannot be pulled out using your fingers. If it can, tighten the connector.



Tightness correct.
Cannot be pulled out.

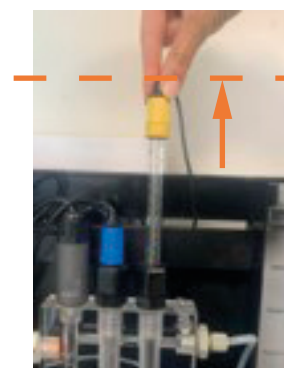

Tightness incorrect.
Can be pulled out.

4.7 Inductive Flow Sensor

The inductive flow sensor indicates whether the flow of water through the probe holder is adequate for correct operation of the control panel.

The inductive flow sensor system alarm is triggered when there is little or no water recirculation (flow) through the panel. The existence of a flow of water is shown as it keeps the float at the level of the inductive sensor. If water flow is interrupted, the float descends and a flow alarm is shown.

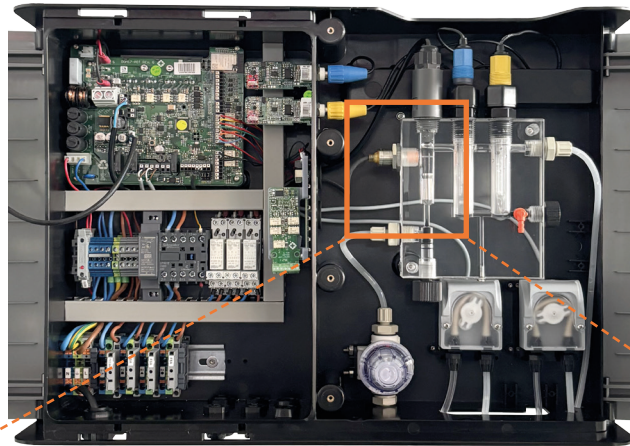

**Recommended
flow**

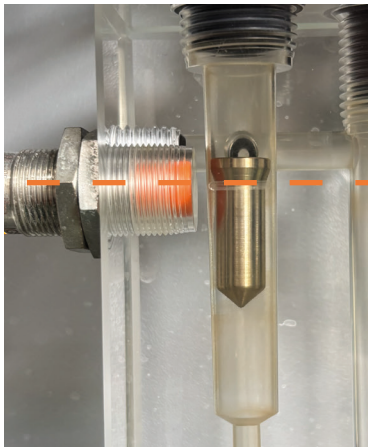

**The float does not reach
the recommended level.
This triggers the alarm.**

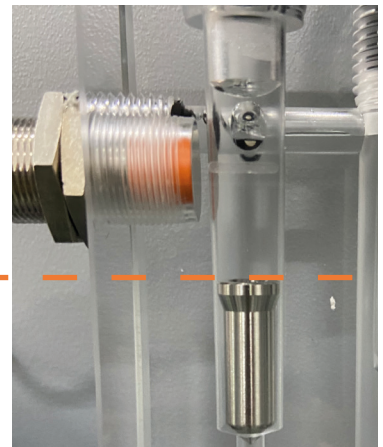

4.8 Initial Start-up

1. Make sure that the recirculation filter is 100% clean and that there is no copper, iron or algae in the pool or equipment.
2. Balance the pool water. This will enable more efficient treatment with a lower concentration of free chlorine in the water.
 - Its pH should be 7.2–7.6.
 - Total alkalinity should be 60–120 ppm.

NOTE: to determine the level of free chlorine, a test kit must be used.

3. In pools that are exposed to strong sunshine or intensively used, it is advisable to maintain a level of 25–30 mg/L of stabiliser (isocyanuric acid). Under no circumstances should a level of 75 mg/L be exceeded. This will help to prevent the destruction of free chlorine in the water by sunlight.

5. User Interface

5.1 Cover and Functions

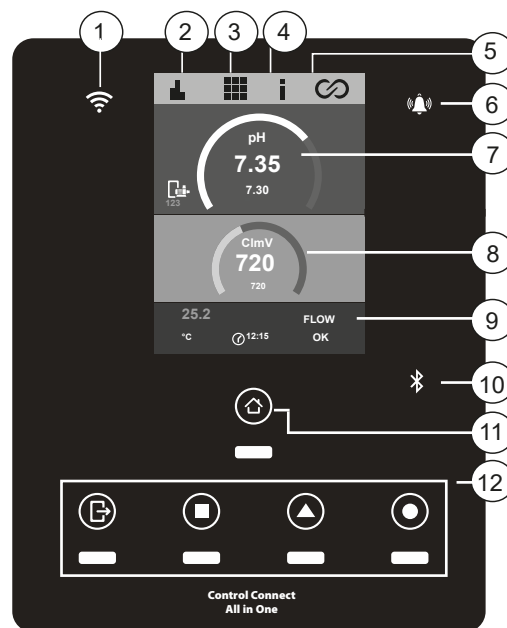

- | | |
|-----------------------|-----------------------------------|
| 1) Wi-Fi status LED | 7) pH |
| 2) Log menu | 8) ORP |
| 3) Configuration menu | 9) Sensors (temperature and flow) |
| 4) Information menu | 10) Bluetooth connectivity |
| 5) Relay menu | 11) Home menu |
| 6) Alarm LED | 12) Relay status |

5.3 Temperature Sensor Configuration

°C

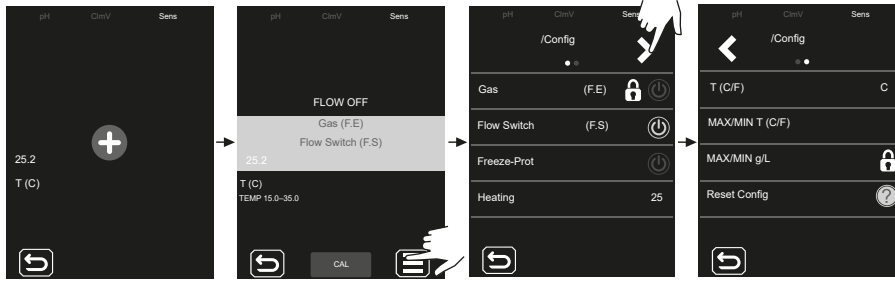
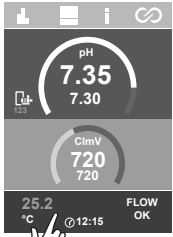

Gas: Enable/disable gas sensor detection. This function will be active whenever saline electrolysis is activated.



Flow switch: Enable/disable flow sensor detection (inductive sensor).

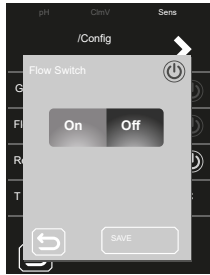

Freeze-Prot: Prevents water from freezing in the pipes. Filtering is switched on if the water temperature drops below the set value (of 1–5 °C). Once the temperature has increased to the set point, filtering stops.



Heating: The heater activates automatically to maintain the desired temperature of the water (default value: 25 °C). The temperature can be set within the range 6–50 °C.

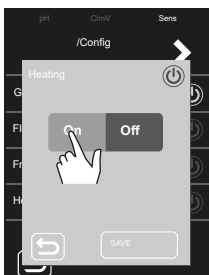

T (C/F): Temperature scale selection – Fahrenheit or Celsius.

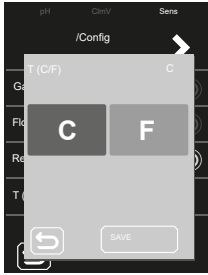

MAX/MIN T (C/F): Sets the maximum/minimum value of the temperature alarm. If the temperature of the pool water is above or below the set range, the temperature alarm will be triggered.

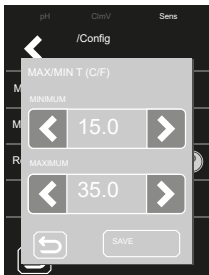

Reset Config: If activated, equipment settings will revert to factory defaults. A message appears showing the values to be changed.

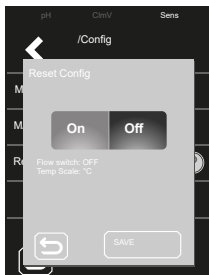

- Flow switch: OFF
- Temp Scale: °C

5.4 pH Configuration

pH

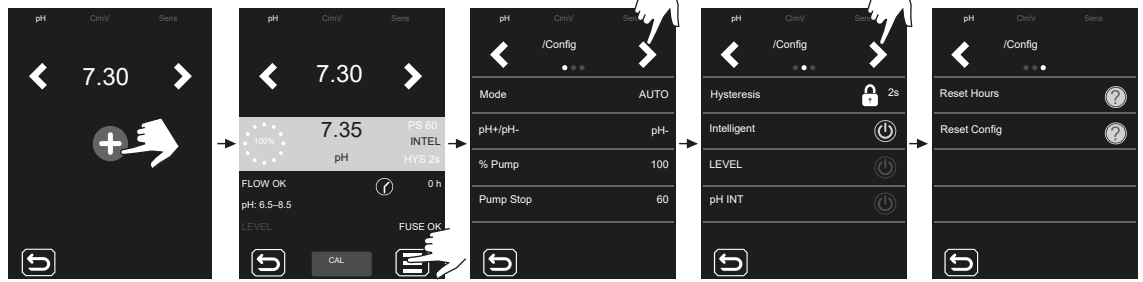
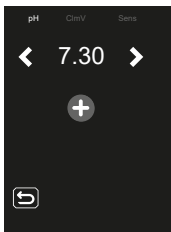
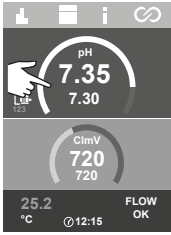

pH: Establishes the set point using the < / > arrows

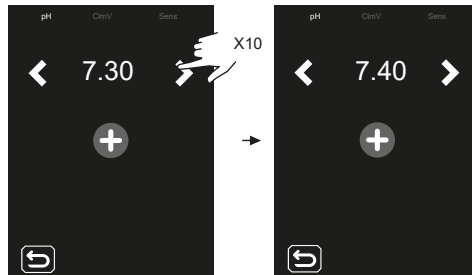

Mode: Sets the pump working mode.

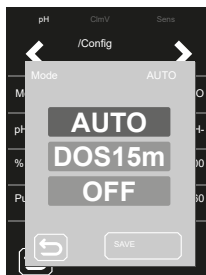

- **AUTO:** This function will switch the pump on when the pH value is above the set point.
- **DOSE:** With this function, pH-Minus is dosed for 15 minutes, regardless of the pH value of the water. It is useful during start-up.
- **OFF:** The pump will never switch on.

pH-: Sets the pH product to be used. When electrolysis is enabled, the non-modifiable value is pH-.

% Pump: Sets the working period of the pump for each minute of dosing. E.g. 50% = 30 s on 30 s off.

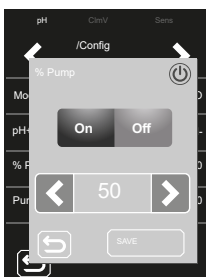

Pump Stop: The pH has a safety system (**PUMP STOP FUNCTION**) which acts on the dosing pump and prevents the following:

- Damage caused by dry running the pump (depleted pH-minus product).
- Overdosage of pH-minus product (damaged or aged sensor).
- pH regulation problems due to high alkalinity of the water (freshly filled pool, high carbonate levels).

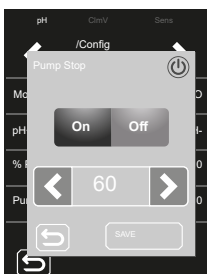

When the **PUMP STOP FUNCTION** is activated (default), the system stops the dosing pump after a time set in minutes without having reached the pH set point.

To reset the **PUMP STOP** alarm, see section 7.3.

Hysteresis: Time (2 s) that the pump continues dosing when the measurement reaches the desired set point (value cannot be changed). 

Intelligent: Smart pH- dosing function for more precise regulation. The working cycle of the pump is updated dynamically depending on the pH measurement.

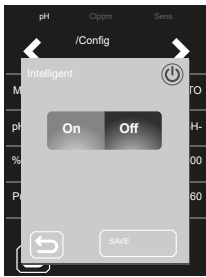

LEVEL: Function for the use of a liquid level sensor (pH-). It will stop the pump dosing if the liquid level is below the level sensor.

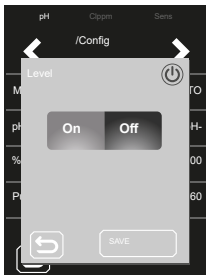

pH INIT: pH reading stabilisation time. After switching on the equipment or changing the status of RELAY1 to ON / AUTO-ON, a time of 1min/2min/4min can be set to obtain a stable pH reading.

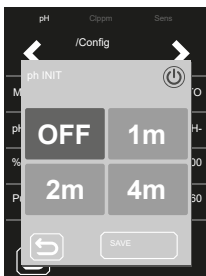

Reset Hours: Resets the pH pump partial hours value.

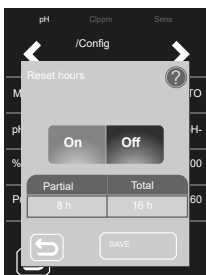

Reset Config: Resets the default configuration parameters. A message appears showing the values to be changed.

- **Mode:** AUTO
- **% Pump:** 100%
- **PS:** 60m
- **HYS:** 2s
- **Intelligent:** ON
- **LEVEL:** ON
- **Set:** 7.20

5.5 Log menu

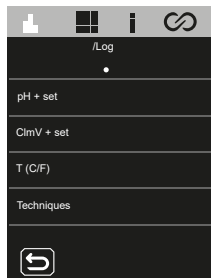
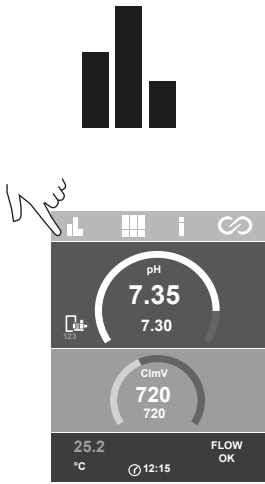

pH + set: pH measurement and set point.

ClmV + set: ClmV measurement (depending on the slot installed) and set point.

T (°C): Water temperature.

Techniques: Records 24 hours/24 days of ClmV measurement and pH measurement.

Statistics show a history of the production parameters – pH, ClmV, T (°C) – during device operation. You can choose between displaying statistics for the last 24 hours or the last 24 days.

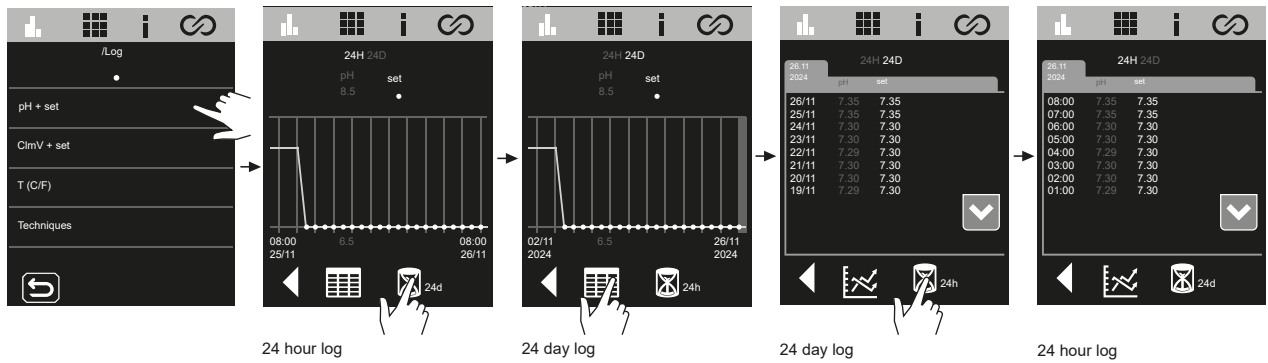

5.6 Configuration Menu

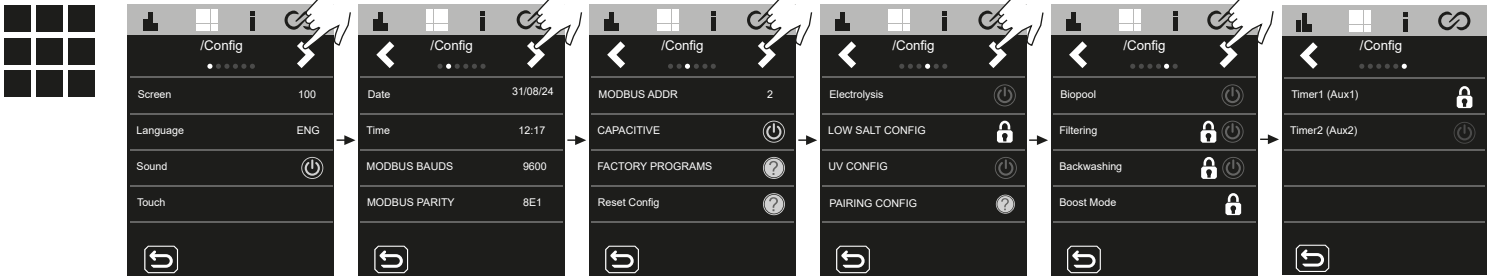

Screen: Sets the screen brightness.

Language: Language selection. Available languages: ESP, FRA, NED, ITA, POR, DEU, POL, ENG.

Sound: Enable/Disable device's sound.

Touch: Touchscreen calibration.

Date: Set day/month/year (equipment date). Not configurable if the device is connected to Fluidra Pool.

Time: Set time. Not configurable if the device is connected to Fluidra Pool.

Modbus Bauds: Sets the MODBUS speed to 9600 or 19200.

Modbus Parity: Sets between 8E1, 8N1, 8N2.

- 8E1: 8 bits, PAR parity, 1 stop bit.
- 8N1: 8 bits, no parity, 1 stop bit.
- 8N2: 8 bits, no parity, 2 stop bits.

Modbus Addr: Configurable MODBUS address (default 2).

Capacitive: Enable/disable capacitive buttons.

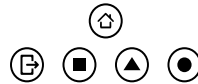

Factory Programs: Restores default relay timing.

- | | | | |
|--------------------|--------------------|--------------------|--------------------|
| - R1a: 04:00–08:00 | - R2a: 08:00–14:00 | - R3a: 10:00–13:00 | - R4a: 03:00–06:00 |
| 21:00–24:00 | - R2b: 10:00–13:00 | 18:00–21:00 | - R4b: 08:00–24:00 |
| - R1b: 08:00–21:00 | | - R3b: 12:00–22:00 | |
| - R1c: 16:00–21:00 | | | |

Reset Configuration: Restores default values:

- **Screen:** 90
- **Language:** English
- **Sound:** Enabled
- **Reset** to tactile calibration factory values.
- **Date and Time:** 01/01/2024 0000
- **Modbus:**
 - Baud:** 9600
 - Parity:** 8E1
 - Addr:** 2

Electrolysis: Enabled by default in electrolysis devices. In this equipment it is disabled.

Low Salt Config: Enabled by default in low salinity devices, disabled in devices for standard salinity or without electrolysis. This function resets the g/L by indicating on the main display that the device is a low salt (LS) system. **Do not activate this function if the device is not a low salt system. Otherwise, the g/L measurement will not be correct.**

UV Config: Enabled by default in the Neolysis system. Displays lamp hours and ballast status.

Pairing configuration: to connect to the Fluidra Pool app. Alternatively, it can be activated by pressing the Home (🏠) menu for 5 seconds.



Connection with Fluidra Pool

1. Download and install the FLUIDRA POOL app.
2. Create a user account and set up the pool parameters.
3. Activate pairing mode in the equipment by pressing Home (🏠) menu for 5 seconds.
4. Press "Add Equipment" and follow the FLUIDRA POOL instructions.

Biopool: Increased range of pH and ClmV settings.

pH: STANDARD = 6.50–8.50 / BIOPOOL = 6.00–9.00

ClmV: STANDARD = 600–855 / BIOPOOL = 300–855

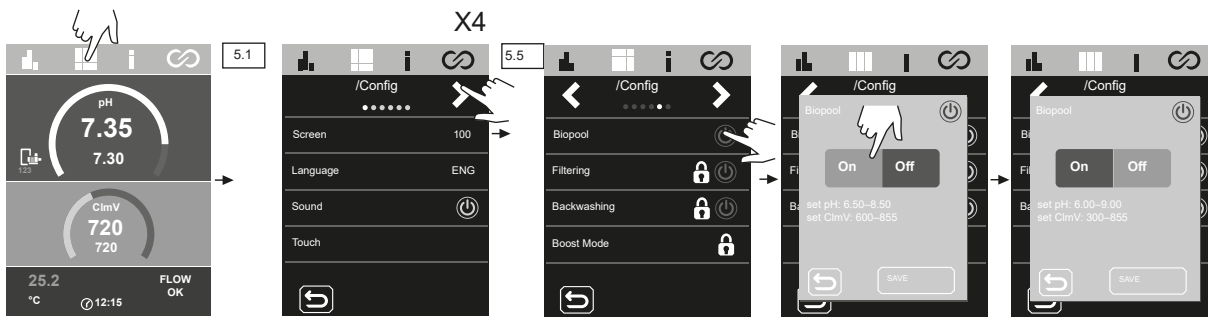

Filtering: This function can only be enabled with the VSP driver (optional accessory). Variable speed pump control.

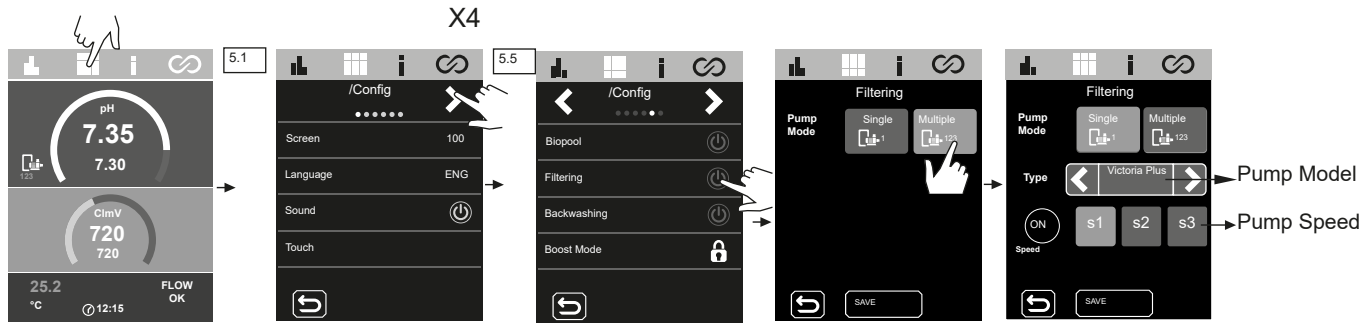

Backwashing: Filter cleaning can be selected manually or cleaning cycles can be programmed. To programme backwashing periods, you can select their speed, frequency and duration. At the top of the menu you can check the date that backwashing was last carried out.

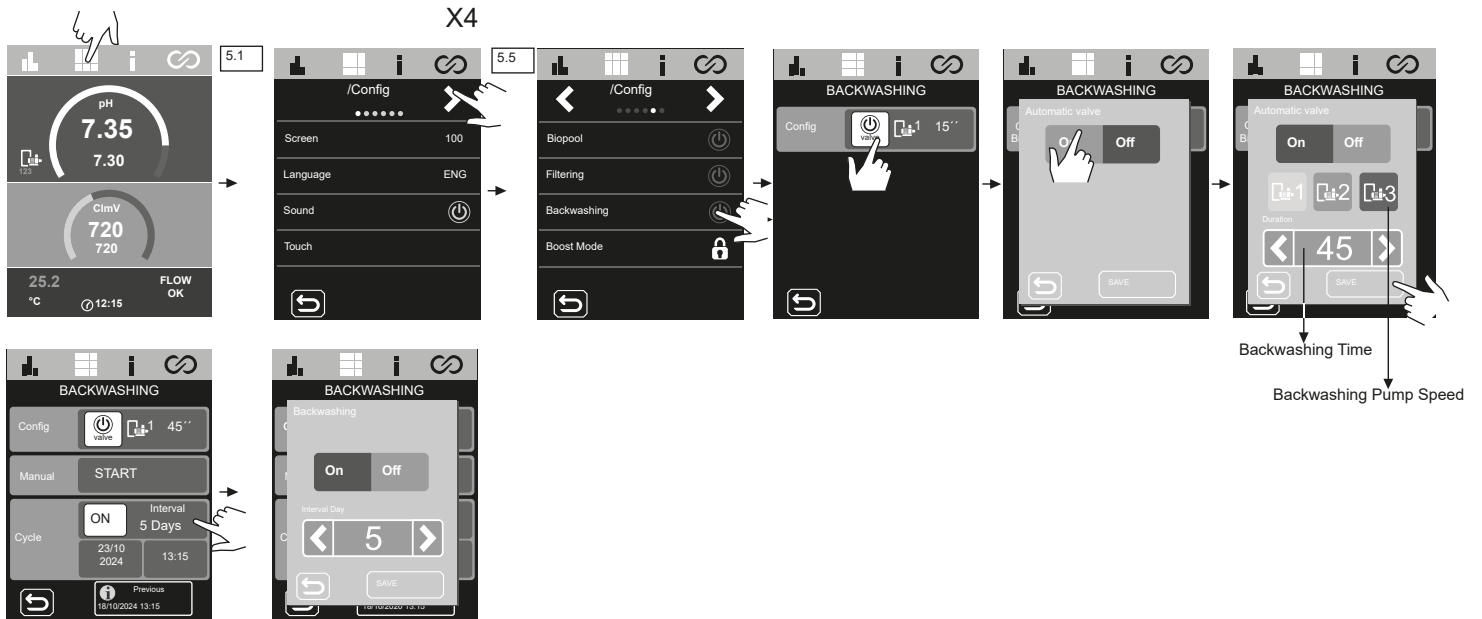

Boost (Shock) Mode: Activates maximum filtering (100%) for 24 hours. After this time, it reverts to the programmed filtering mode. Disabled by default in devices without electrolysis.

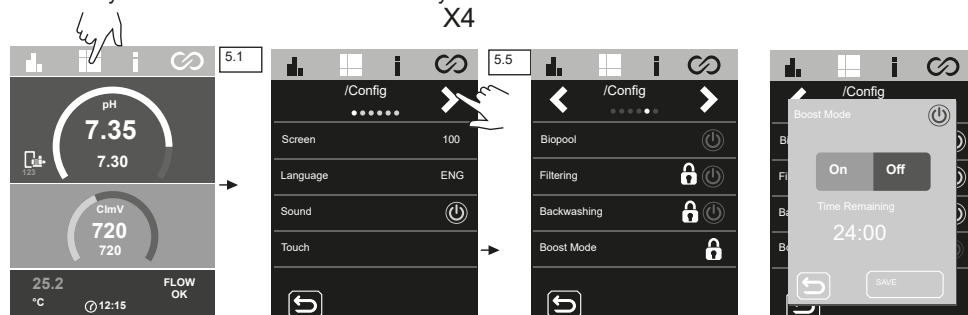

Timer 1-2 (AUX 1-2):

For configuring one additional auxiliary relay with associated timers (e.g. flocculant dosing pumps, lighting, BW, etc.). This function allows selection among manual, automatic, cycles and BW (backwashing) options.

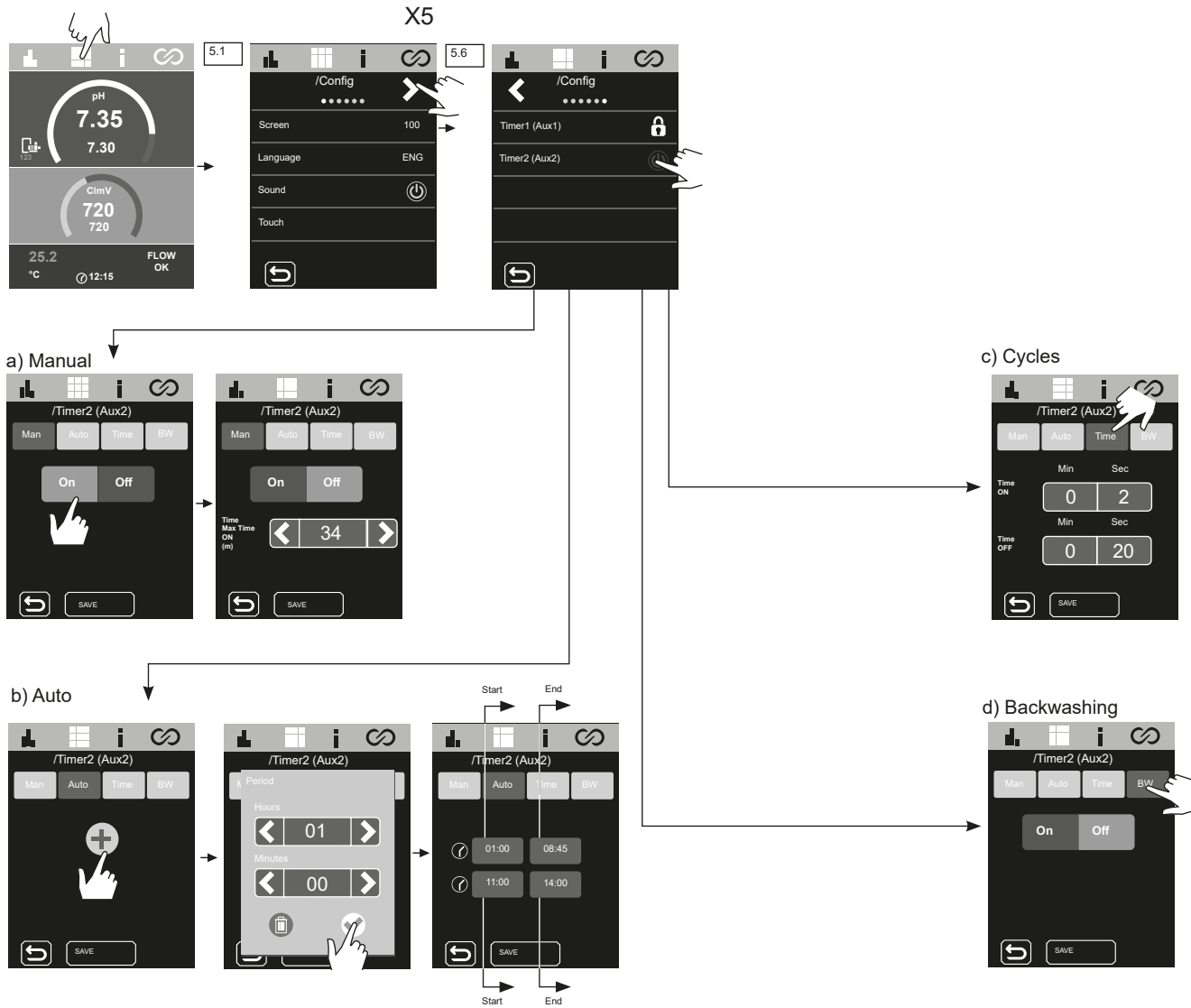

5.7 Information Menu

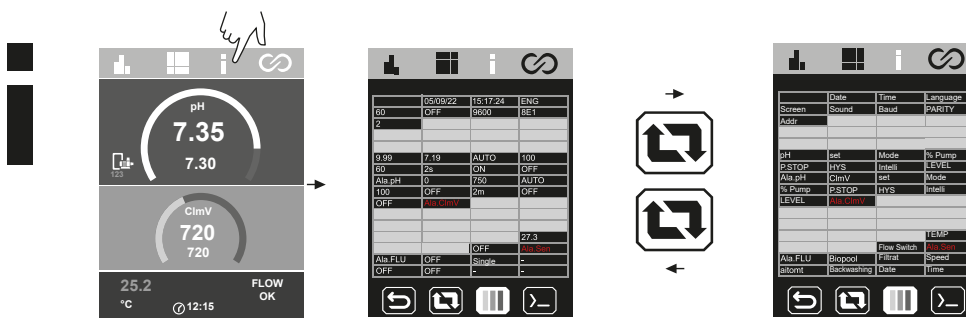

The information menu will show all the equipment's values on a single screen.

5.8 Relays Menu (Fluidra Pool)



Allows relay programs to be modified and interlocks to be set if necessary.

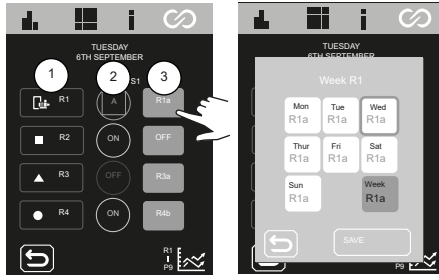
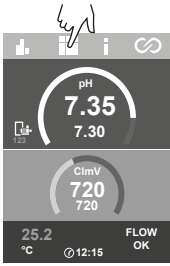

1) Relay selection

2) Relay mode

- Automatic mode (programmed)



- Relay on



- Relay off



3) Select the programs.

Program modification:

Relays R1–R4 have 9 different configurable programs:

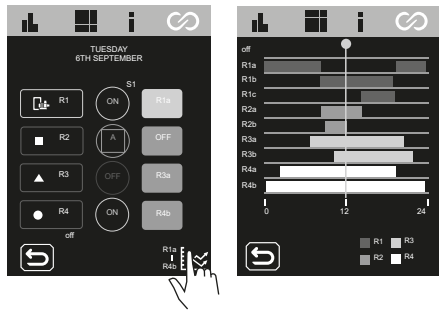

R1: R1a

R1b

R1c

R2: R2a

R2b

R3: R3a

R3b

R4: R4a

R4b

Each program has 4 time slots to be configured.

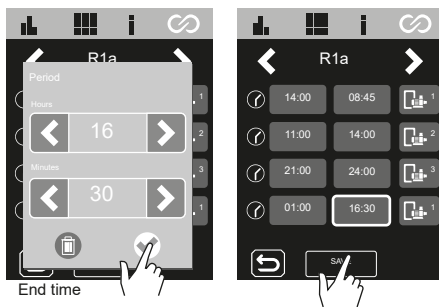
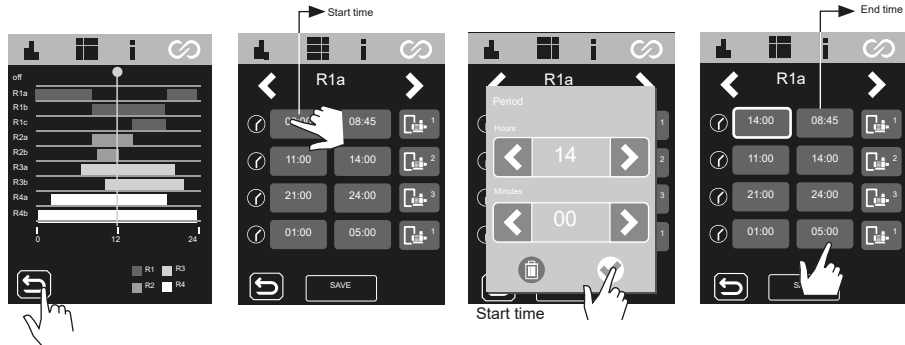

If the VSP is connected (optional), R1 (R1a–c) can be used to set various speeds (S1,S2,S3)

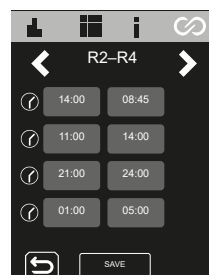

R2–R4 only allow a single set speed.

Relay interlocking:

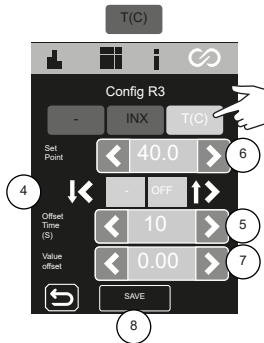
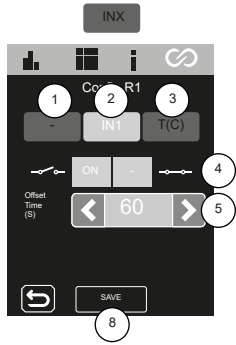
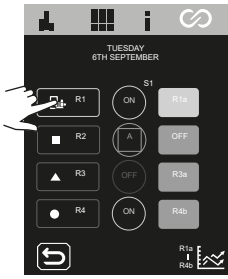

- 1) No interlocking.
- 2) Digital interlocking selection (IN1, IN2, IN3, IN4).
- 3) Analog interlocking selection: temperature.
- 4) Digital input status

- No interlocking.
- ON When the contact is open/closed, the relay will switch to ON.
- OFF When the contact is open/closed, the relay will switch to OFF.
- AUTO When the contact is open/closed, the relay mode will switch to AUTO.

- 5) Time OFFSET configuration: 0 ... 999 s.
Time interval for setting the relay status ON / OFF / AUTO.
- 6) Temperature set point value configuration: 0 ... 40°.
- 7) OFFSET value configuration: 0 ... 10°.
Temperature range for setting relay status ON / OFF / AUTO.
- 8) Save changes.

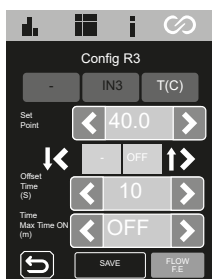
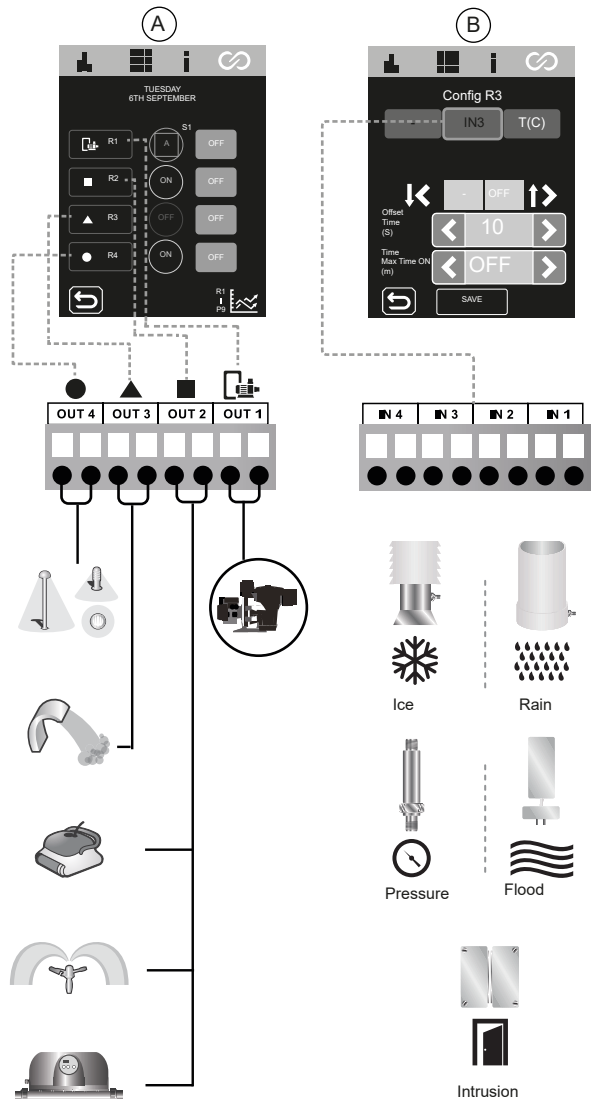
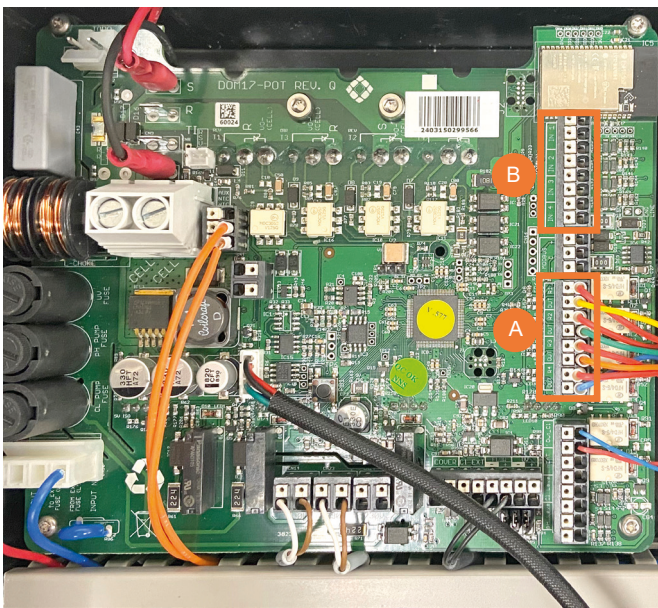

This function stops relay safety interlocking when a flow (FS) or gas (FE) alarm appear.

5.9 ClmV Configuration

ClmV

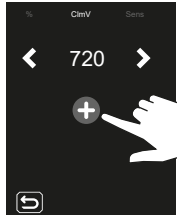
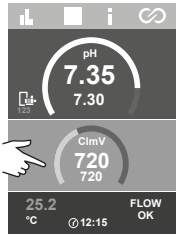

ClmV: Establishes the set point using the < / > arrows.

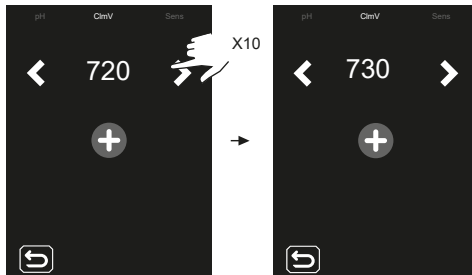

Mode: Sets the pump working mode.

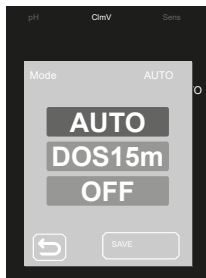

- **AUTO:** This function will switch the pump on when the ClmV value is below the set point.
- **DOSE:** With this function, the product is dosed for 15 minutes, regardless of the ClmV value of the water. It is useful during start-up.
- **OFF:** The pump will never switch on.

OXD/RED: Oxidiser/Reducer configuration.

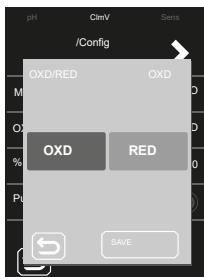

% Pump: Sets the working period of the pump for each minute of dosing. E.g. 50% = 30 s on 30 s off.

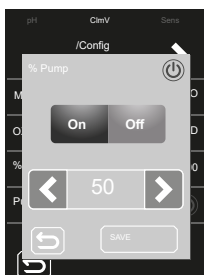

Pump Stop: ClmV has a safety system (**PUMP STOP FUNCTION**) which acts on the dosing pump and prevents the following:

- Damage caused by dry running the pump (depleted CI product).
- CI product overdose (damaged or old sensor).

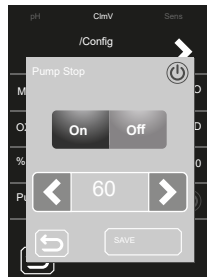

When the **PUMP STOP FUNCTION** is activated, the system stops the dosing pump after a time set in minutes without having reached the CI set point.

Hysteresis: Time during which the pump continues dosing when the measurement reaches the desired set point.

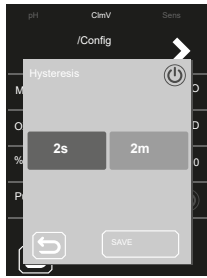

Intelligent: Smart ClmV dosing function for more precise control. The working cycle of the pump is updated dynamically depending on the measurement.

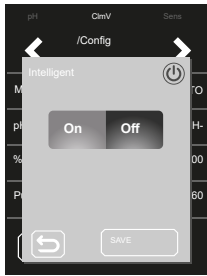

LEVEL: Function for the use of a liquid level sensor (CI). It will stop the pump dosing if the liquid level is below the level sensor.

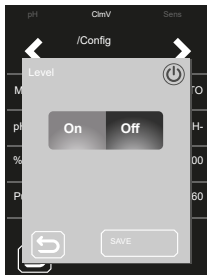

Reset Hours: Resets the pump partial hours value.

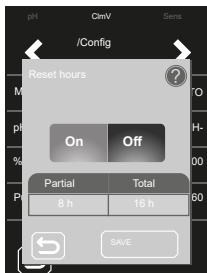

Reset Config: Resets the default configuration parameters. A message appears showing the values to be changed.

- **Mode:** AUTO
- **% Pump:** 100%
- **PS:** OFF
- **HYS:** 2m
- **Intelligent:** ON
- **LEVEL:** ON
- **Set:** 750

6. Sensor Calibration (pH, ORP, temperature)

6.1 Fast pH Calibration

'Fast' mode allows routine recalibration of the sensor when there are small errors in calibration with no need to remove the sensor or use calibration solutions.

PROCEDURE:

1. Ensure that the sensor is immersed in water and that the filter system is running.
2. Use a pH kit to measure the existing pH of the water in the pool.
3. Follow the procedure shown in the pictures below:

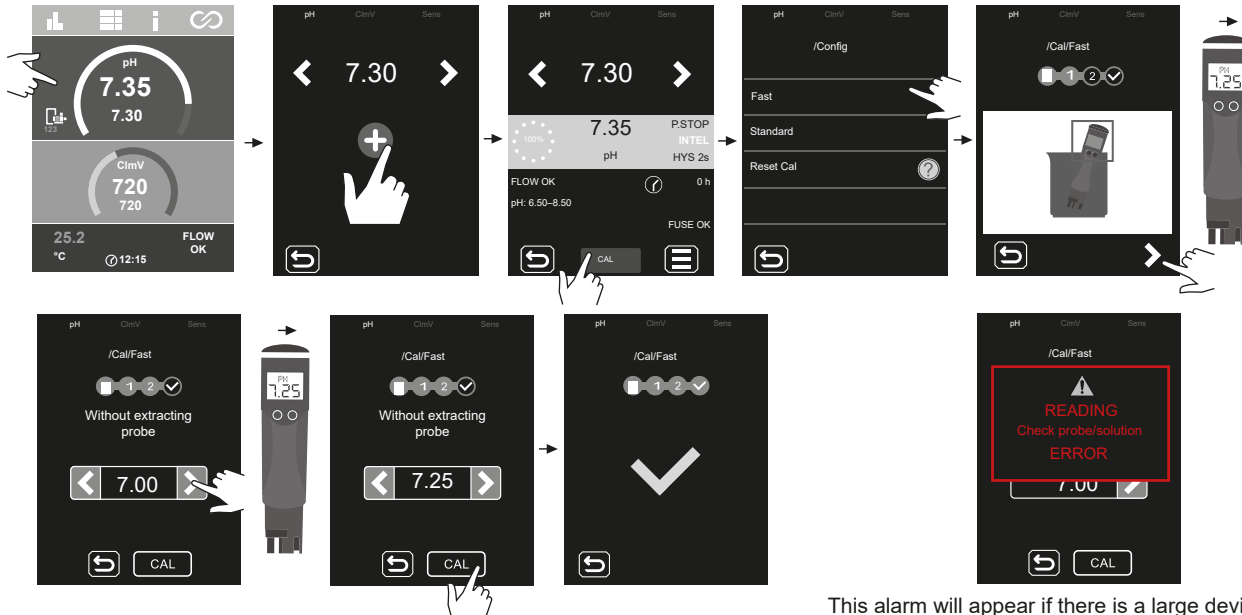

This alarm will appear if there is a large deviation (± 1 pH unit) during calibration.

6.2 Standard pH Calibration

'Standard' mode allows precise calibration of the sensor using two control solutions with pH 7.0 and pH 4.0. However, this requires that the sensor be removed from the installation.

PROCEDURE:

PLEASE NOTE: Before calibrating the sensors, close the panel inlet and outlet valves. If the equipment is using saline electrolysis, stop the equipment's production before closing the panel inlet and outlet valves.

1. Remove the sensor from the probe holder and rinse it in an abundance of water.
2. Follow the procedure shown in the pictures below:

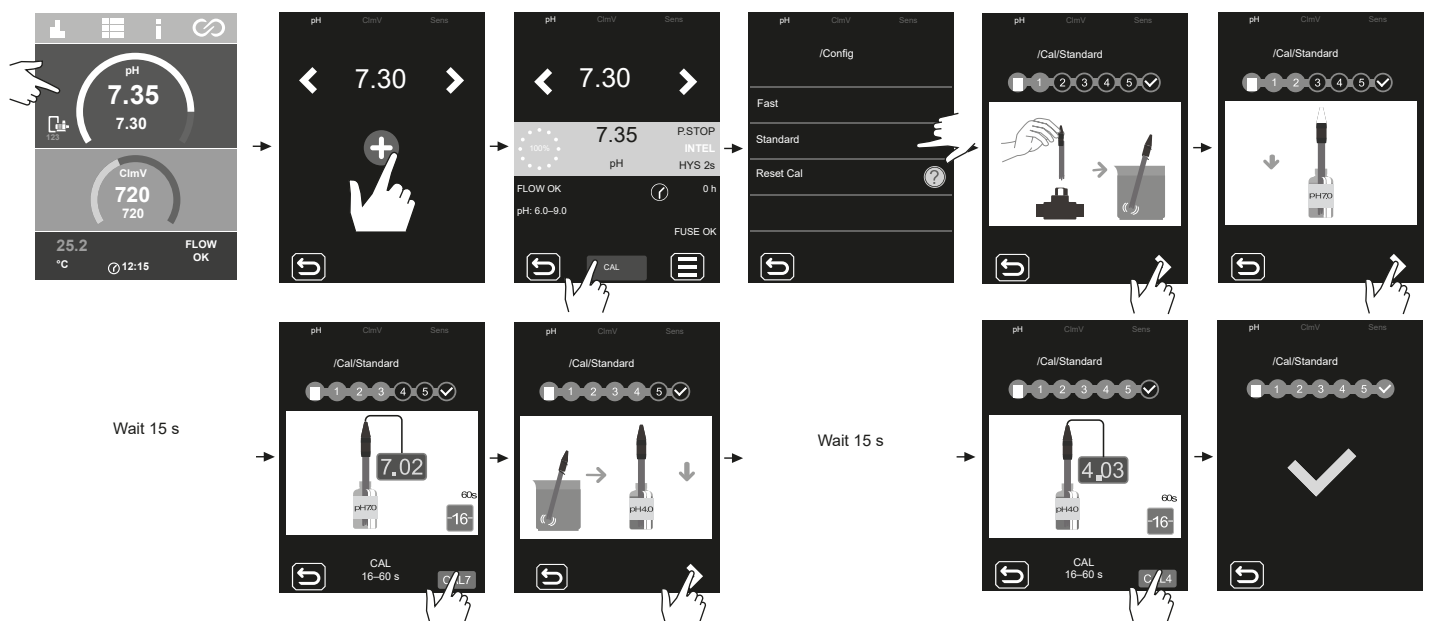

6.3 Standard ClmV Calibration (ORP)

The controller's calibration frequency must be individually determined in each application. However, we recommend this be done at least once a month while the swimming pool is in use. ClmV has an automatic calibration system for ORP sensors based on the use of a 470 mV control solution.

PROCEDURE:

PLEASE NOTE: Before calibrating the sensors, close the panel inlet and outlet valves. If the equipment is using saline electrolysis, stop the equipment's production before closing the panel inlet and outlet valves.

1. Remove the ORP sensor from the holder and rinse it with tap water.
2. Follow the procedure shown in the pictures below:

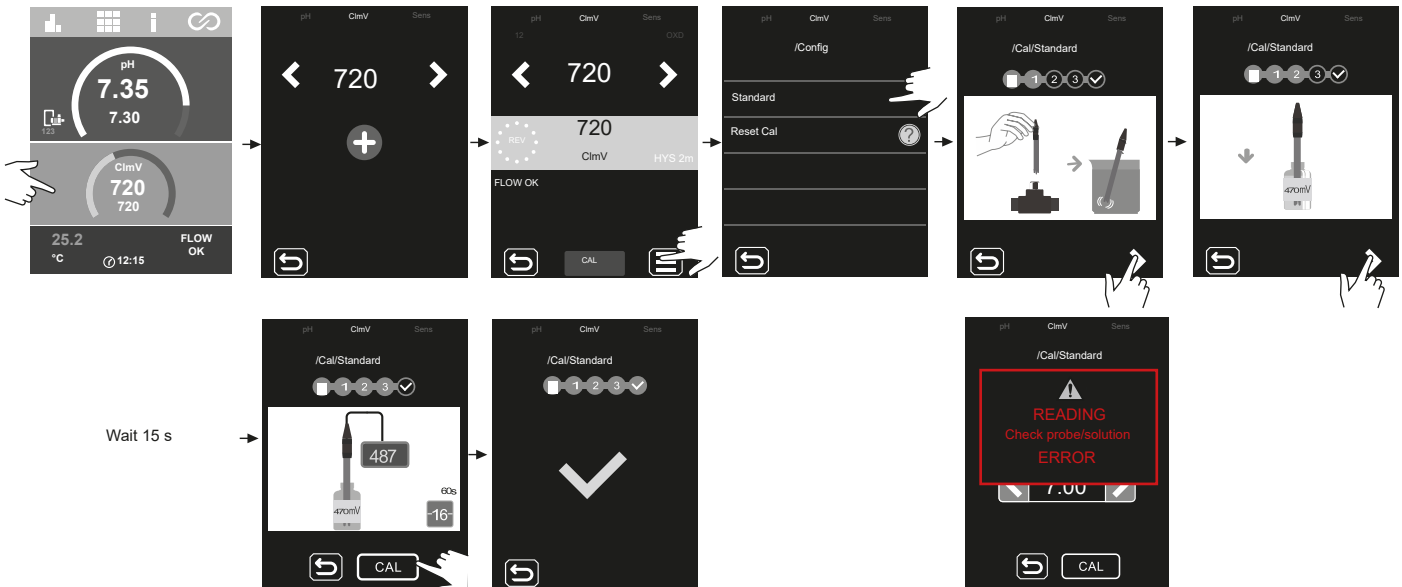

This alarm will appear if there is a large deviation (± 60 mV in a 470 mV solution) during calibration.

6.4 T (°C/°F) Calibration

Temperature calibration makes it possible to adjust the value in the event of small temperature deviations.

PROCEDURE:

1. Use an external temperature sensor to measure the current value of the pool water.
2. Follow the procedure shown in the pictures below:

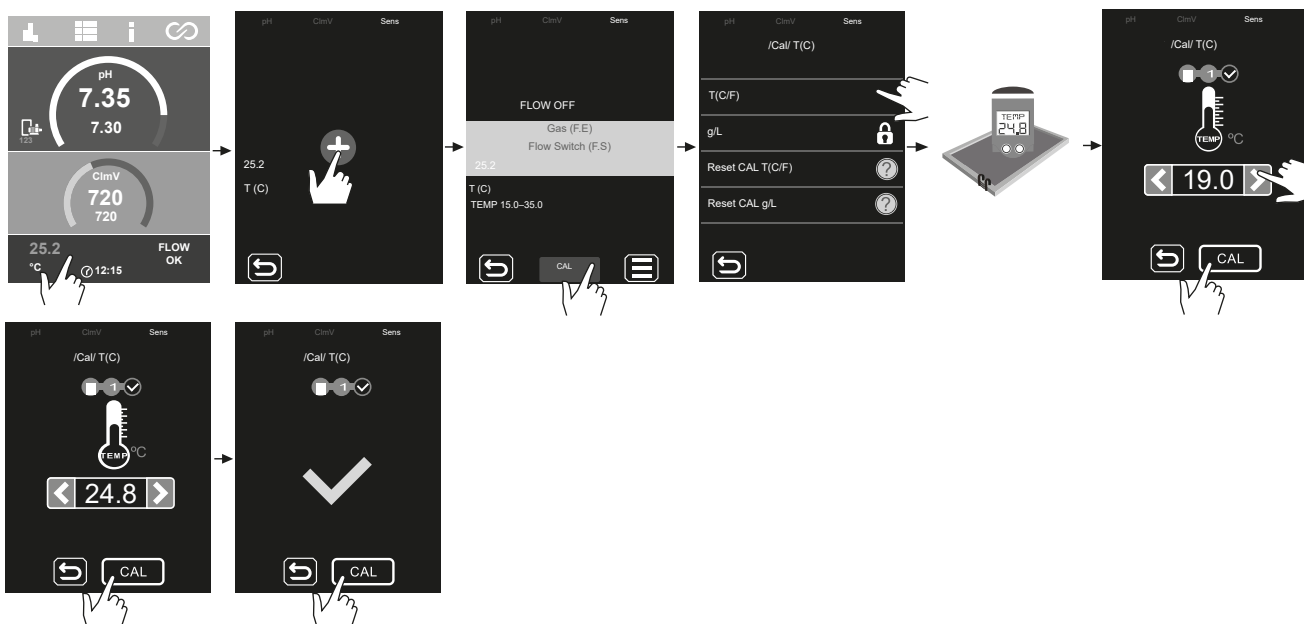

7. Alarms

The red LED on the control panel signals an alarm.

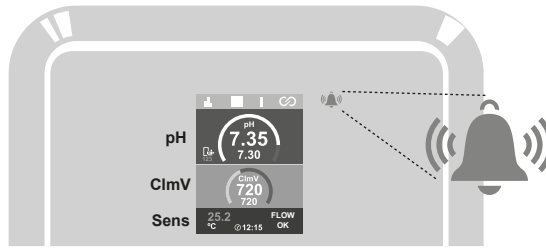

- Ext Text in grey = Option disabled
- Int White text = Option enabled
- grid Text in red = Alarms

Sens

7.1 Temperature alarm

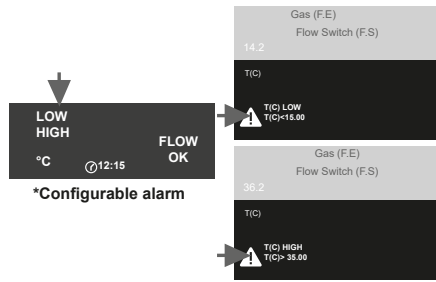

7.2 Inductive/Flow Switch Sensor Alarm



pH

7.3 pH alarm

Low/high pH alarm



Pump Stop alarm

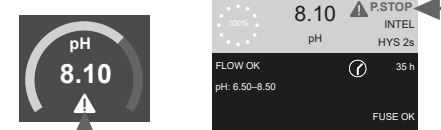

Check Pump alarm

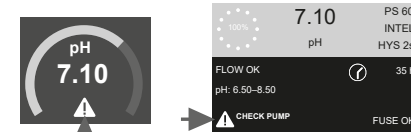

Level alarm

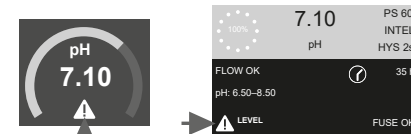

Fuse alarm

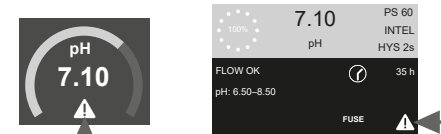

ClmV

7.4 ORP (mV) High/Low Alarm



7.1 Temperature Sensor Alarm

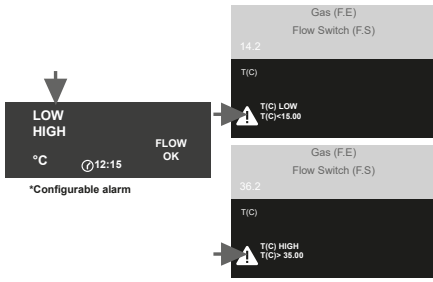

The temperature alarm will appear when temperature values are outside the range set by the user.

When electrolysis is activated, if the water temperature is very low the equipment will not reach 100% production due to low conductivity.

Temperature sensor – temperature range configuration (max/min).

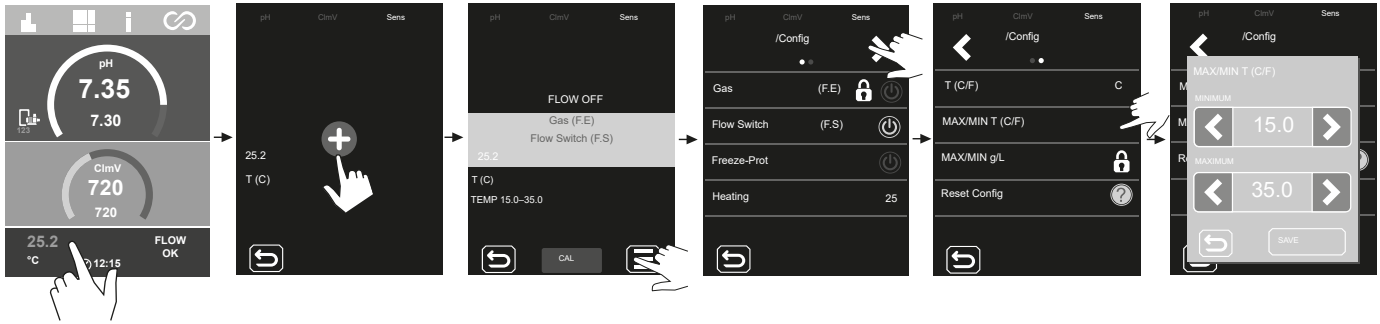

7.2 Inductive/Flow Switch Sensor Alarm



The flow alarm will appear if there is no water flow (inductive or flow switch sensor).

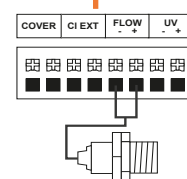
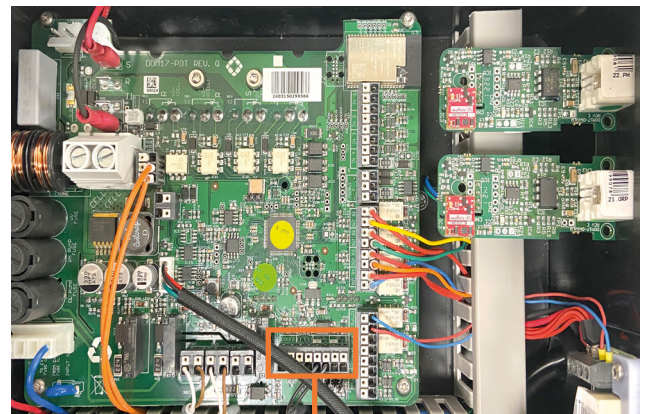
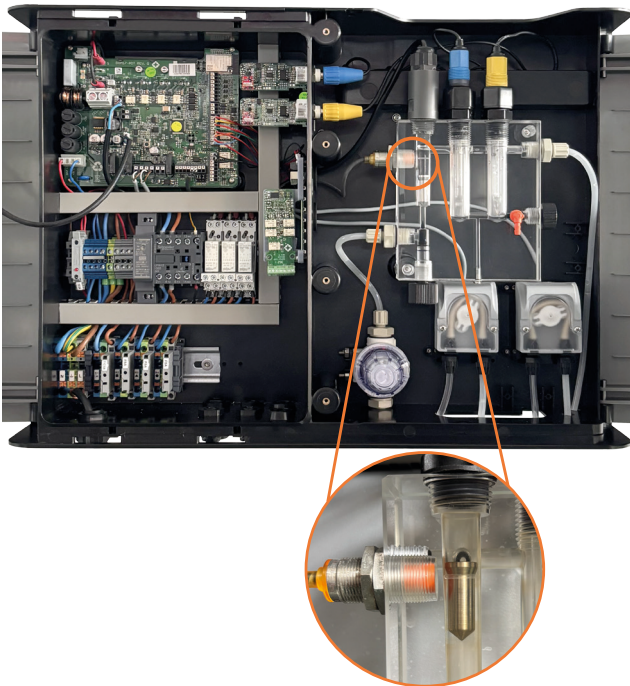

When the contact connected to this input is open (flow detector idle) and the [FS] alarm is triggered in the equipment, the electrolysis system switches off due to the flow alarm.

7.3 pH Alarms

pH – Low/high alarm



Low or high alarms appear if the pH reading is outside the set values. These values cannot be modified.

If the high pH alarm appears, the pH pump will be switched off according to the safety values set.

Standard mode

pH > 8.5 = pH HIGH ALARM = Pump off
pH < 6.5 = pH LOW ALARM

Biopool mode

pH > 9.0 = pH HIGH ALARM = Pump off
pH < 6.0 = pH LOW ALARM

The pH of the pool must be manually reduced to 8.45 (standard mode) or 8.95 (biopool mode) for the pump to start dosing again.

pH – Pump-stop alarm

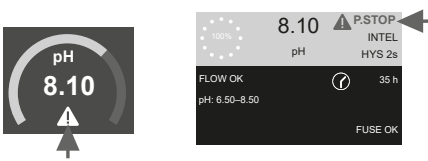

The in-built pH system has a safety feature (PUMP-STOP) that acts on the dosing pump and prevents the following situations.

- Damage caused by dry running of the pump (depleted pH-minus product).
 - Overdosage of pH-minus product (damaged or aged sensor).
 - pH regulation problems due to high alkalinity of the water (freshly filled pool, high carbonate levels).
- When the PUMP-STOP FUNCTION is activated (default), the system stops the dosing pump after a programmed time without having reached the pH set point.

The PUMP-STOP FUNCTION is factory set to 60 minutes.

Reset the PUMP-STOP alarm

After resetting the PUMP-STOP alarm, the pump will restart if the pH value is above 0.02 of the set point and below 9.0.

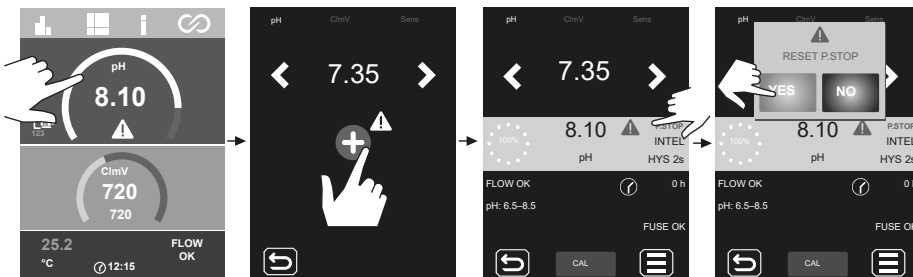

PUMP-STOP function configuration

ON – OFF.
Value: 0...120 min.



pH - Check Pump alarm

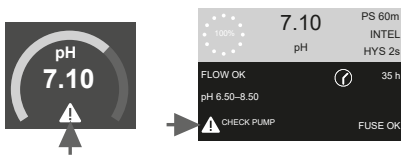

The Check Pump alarm is a visual warning to check the condition of the peristaltic tubing.

- This alarm will appear every 500 hours (not configurable value) but will not affect the start/stop of the pump.
- To clear the alarm, reset the pump's partial dosing hours to zero.

Restart dosing pump hours

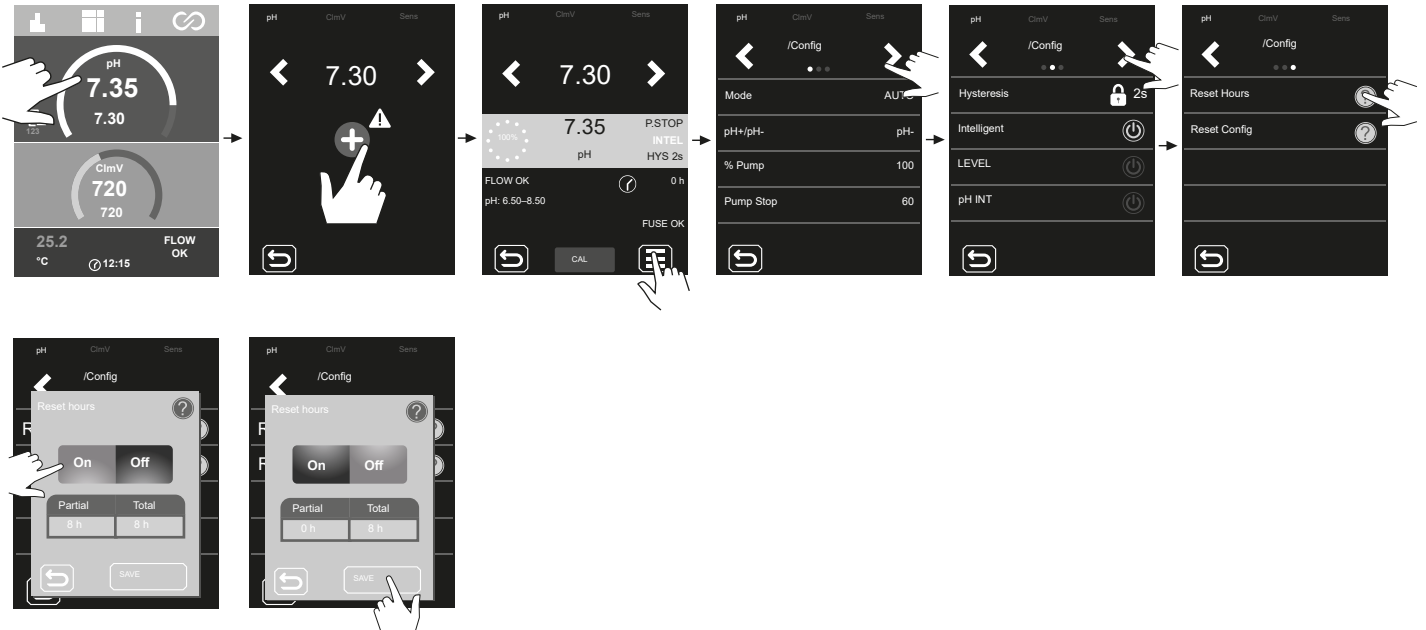

pH - Level sensor alarm (container)

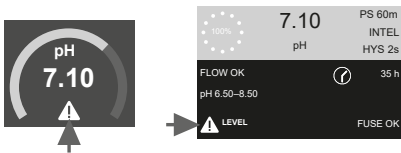

The level sensor is an electronic device that measures the height of liquid in a tank or other container. Generally, this type of sensor functions as an alarm, indicating the low level alarm.

Operating logic:

- Level above the set level = closes the contact
- Level below set level = opens contact and displays level alarm.

Level sensor connection (container)

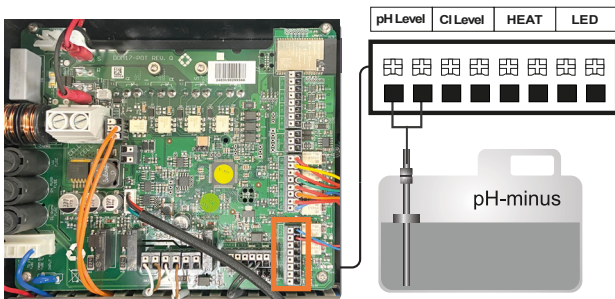

Level sensor ON/OFF (container)

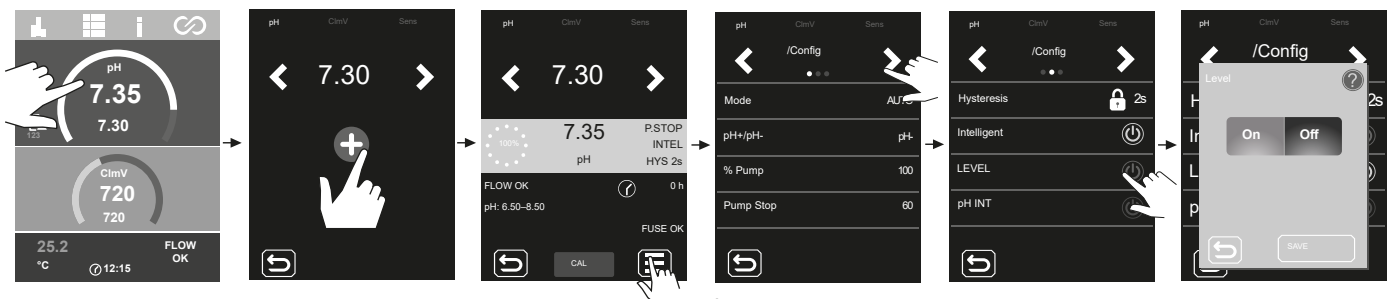

pH – Fuse alarm

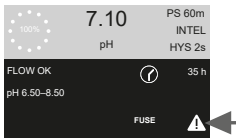
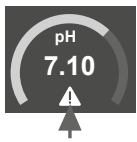

This alarm will appear when the internal fuse of the board is blown.

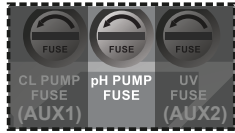

Check the fuse and replace it with a new one.

Fuse type "T" (delayed fusing)

T 500mA

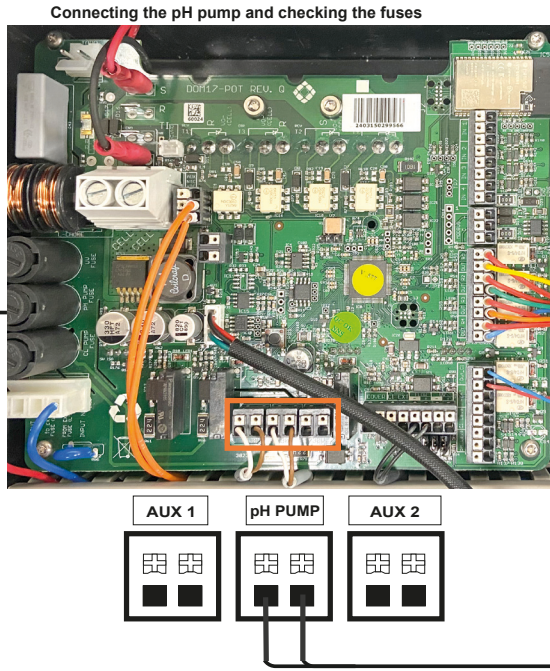

pH peristaltic pump connection

7.4 ORP (mV) High/Low Alarm

mV alarm

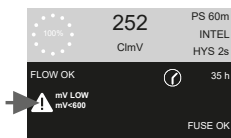
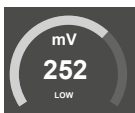

- Low or high alarms appear if the reading is not within established safety limits. High and low ClmV values cannot be changed.

- If the ClmV high alarm appears, dosing will stop. For saline electrolysis equipment, production will stop.

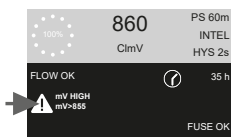
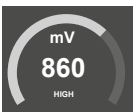

The factory-set ranges are:

Standard:

ClmV > 855 = ORP HIGH ALARM = Dosing is stopped

ClmV < 600 = ORP LOW ALARM

Biopool:

ClmV > 855 = ORP HIGH ALARM = Dosing is stopped

ClmV < 300 = ORP LOW ALARM

7.5 Basic Troubleshooting

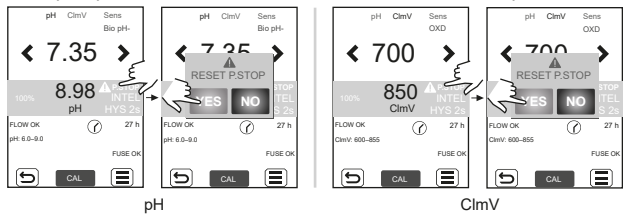
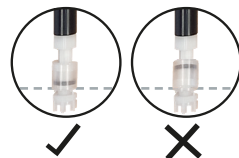

See complete manual for information on:
 • Configuring the alarms

| Message | Solution |
|--|---|
| Inductive FLOW alarm (FS) | The flow alarm will appear if there is no water flow (inductive flow sensor). - Check the pump, filter and backwash valve. Clean if necessary. - Check the flow sensor wiring connections. |
| ORP(mV) – High/low alarm | Low or high alarms appear if the reading is not within established safety limits. High and low ClmV safety limits cannot be changed. Standard mode: ClmV > 855 = HIGH ORP ALARM Biopool mode: ClmV > 855 = HIGH ORP ALARM Check the level of chlorine in the pool using a photometer or a test strip. If necessary, clean and calibrate the ORP sensor. If the free chlorine value is low and the total chlorine value is high, reduce the chloramines by superchlorinating with sodium hypochlorite. If the deviation is high during the calibration process, the equipment will report an error and the probe must be replaced. Standard mode: ClmV < 600 = LOW ORP ALARM Biopool mode: ClmV < 300 = LOW ORP ALARM Check the level of chlorine in the pool using a photometer or a test strip. If necessary, clean and calibrate the ORP sensor. If chlorine ppm are high and the mV reading is low, check cyanuric acid concentration. Should the values be above 60 ppm, partially drain the pool. Increase daily filtering. If the deviation is high during the calibration process, the equipment will report an error and the probe must be replaced. |
| pH Low/High alarm | Low or high alarms appear if the reading is not within established safety limits. These safety limits cannot be changed. If the high pH alarm appears, the pH pump will be switched off for safety reasons. Standard mode: pH > 8.5 = pH HIGH ALARM = Pump off Biopool mode: pH > 9.0 = pH HIGH ALARM = Pump off Check the pH of the pool water using a photometer or a test strip. If necessary, clean and calibrate the pH sensor. If the deviation is high during the calibration process, the equipment will report an error and the probe must be replaced. The pH of the pool must be manually reduced to 8.45 (standard mode) or 8.95 (biopool mode) for the pump to start dosing again. Standard mode: pH < 6.5 = LOW pH ALARM Biopool mode: pH < 6.0 = LOW pH ALARM Check the pH of the pool water using a photometer or a test strip. If necessary, clean and calibrate the pH sensor. If the deviation is high during the calibration process, the equipment will report an error and the probe must be replaced. |
| Low/High Temperature Sensor Alarm | - The temperature alarm will appear when the temperature values set by the user (1.Sens/1.4 Max.-Min. T(C/F)) are out of the programmed range. |
| PUMP-STOP alarm | When the P.STOP FUNCTION for pH and ORP is activated (default 60 min), the system stops the dosing pump after a programmed time without having reached the pH and ORP set point, triggering the PUMP-STOP alarm. - Check the pool's pH and ORP values using a photometer or a test strip. - If necessary, clean and calibrate the pH and ORP sensors. - Check and adjust the alkalinity of the water (consult your pool specialist). - Check the levels of acid in the container. To restore the Pump-Stop function, reset the alarm in the relevant menu: - 2.2 P.STOP-alarm / RESET P.STOP. The pump will restart if the pH value is above the set point and below 9.0. - 7.2 P.STOP-alarm / RESET P.STOP. The pump will restart if the ORP value is below the set point. <div style="text-align: center;"> <p>Reset the PUMP-STOP alarm.</p>  </div> |
| Level Alarm | The level alarm appears when there is no chemical product left in the containers. - Check the level of the chemical dosing containers. If empty, refill accordingly. - Verify that the float on the level sensor is positioned correctly. The black mark should be at the bottom of the float. <div style="text-align: right;">  </div> |

8. Maintenance

pH/ORP Sensor Maintenance (Maintenance 2–12 months).

1. Regular visual inspections are recommended to check that the sensors are in good condition.
2. Ensure that the sensor membrane is always damp.
3. If a sensor is not going to be used for an extended period of time, store it in a storage solution.
4. To clean a sensor, do not use abrasives that could score its surface.
5. Should the dirt not come off using a soft damp cloth, a cleaning solution may be used.
6. Sensors are consumable items that must be replaced after a certain period of use.

Pipe Maintenance (Maintenance 3–6 months).

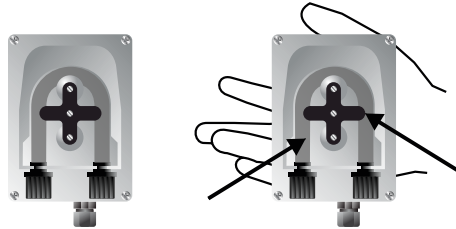

CHECKING THE TUBE AND ROTOR

pHminus (ACID): 2–12 MONTHS

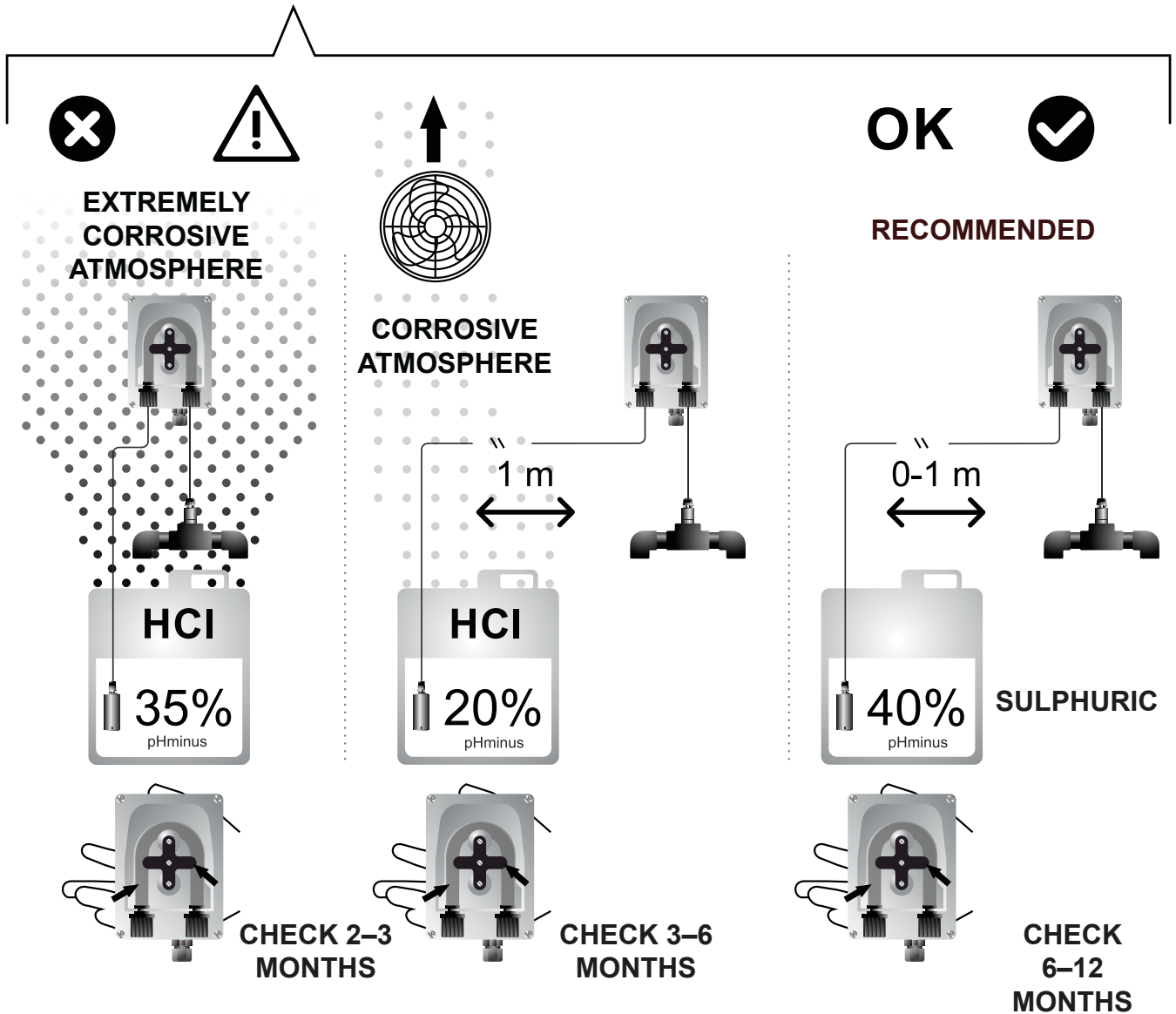

9. Appendices

1) Pump controlled by Fluidra Pool (with Internet connection)

CONTROL CONNECT ALL IN ONE SYSTEM ALWAYS ON AT 230 V
 PUMP CONTROLLED BY R1-FLUIDRA POOL

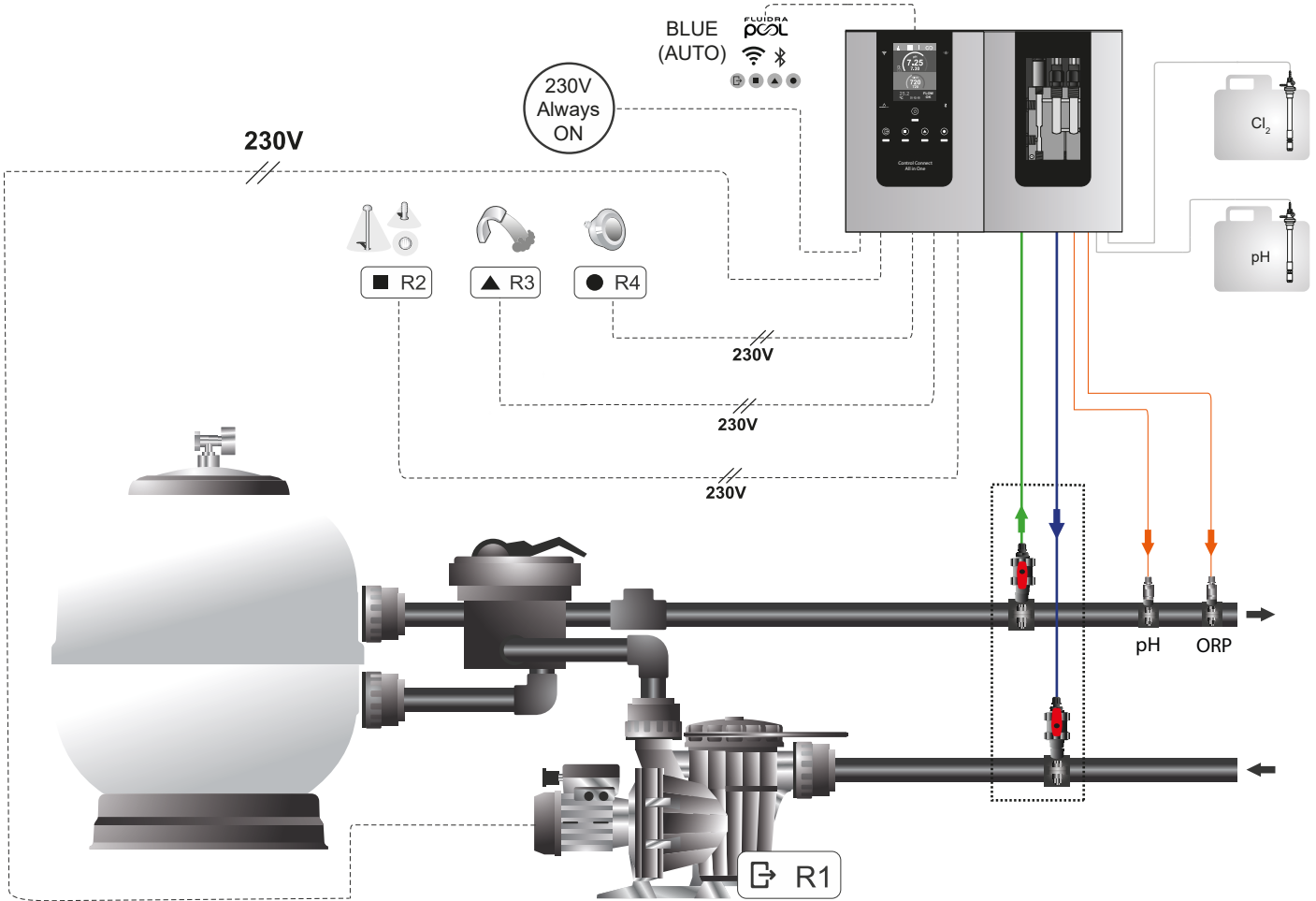

Relay settings can be changed using the relay configuration menu in the All in One equipment or the Fluidra Pool app.

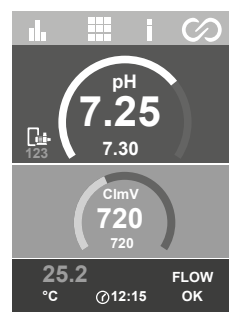
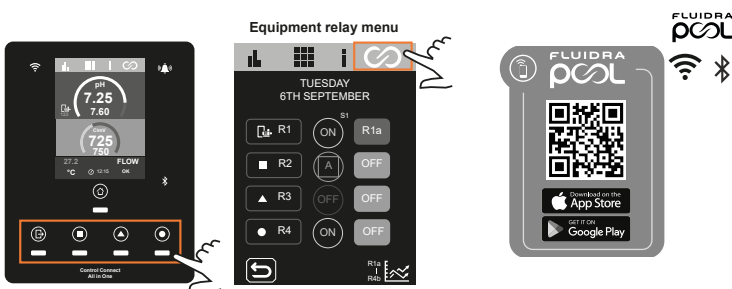

Pump ON
 Treatment ON
 Fluidra Pool ON

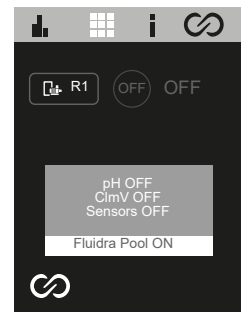

Pump OFF
 Treatment OFF
 Fluidra Pool ON

- Prog R1
- Prog R2
- Prog R3
- Prog R4

RECOMMENDED FOR NORMAL USE



NOT RECOMMENDED



MAINTENANCE

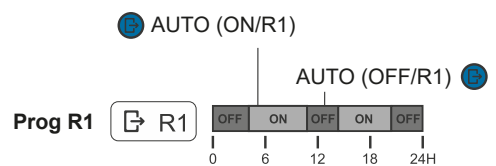

2) Pump and ALL IN ONE system controlled by external timer (stop-run)

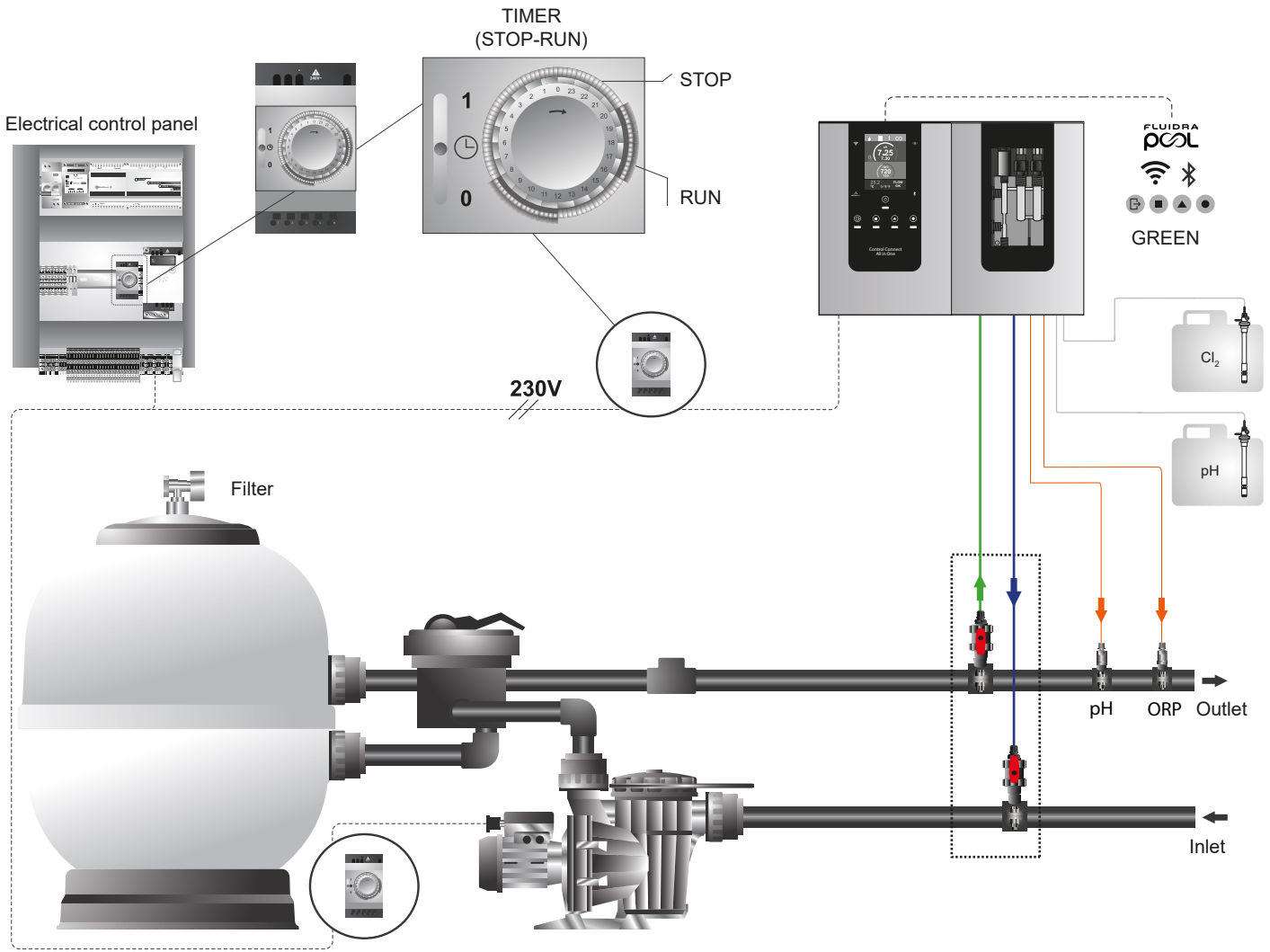

May be used with or without an Internet connection.

Internet connection is only available when TIMER is ON.

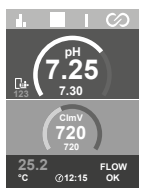

Pump ON (Timer: ON)
Treatment ON
Fluidra Pool ON

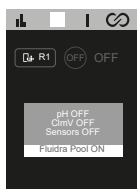

PUMP ON (Timer: RUN)
Treatment OFF
Fluidra Pool ON

NOT RECOMMENDED

AUTO

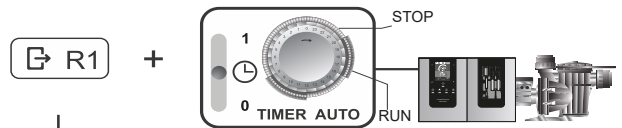

RECOMMENDED

ON

TIMER: AUTO + R1: ON

If "TIMER: AUTO(RUN)": Treat. Active + (Fluidra Pool Active & PUMP ON).

OFF

TIMER: AUTO + R1: OFF

If "TIMER: AUTO(RUN)": Treat. not active + (Fluidra Pool Active & PUMP ON).

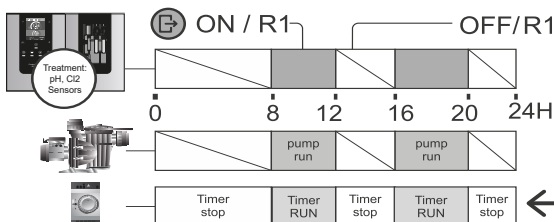

EXTERNAL TIMER

AUTO (stop-run)

ON= 8-12 h + 16-20 h

(EXAMPLE)

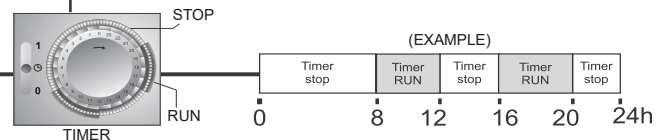

3) ALL IN ONE electronic board

① Temperature sensor

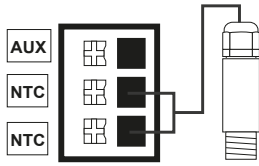

② pH/ORP pumps

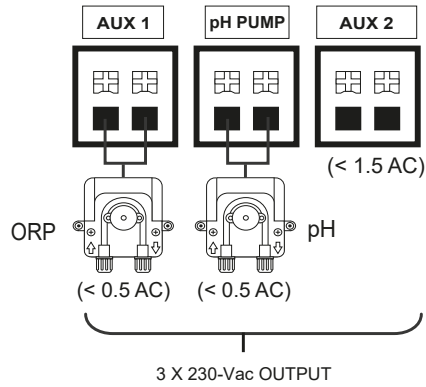

③ Inductive flow sensor

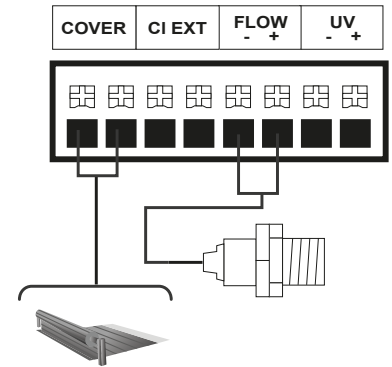

④ Level sensor

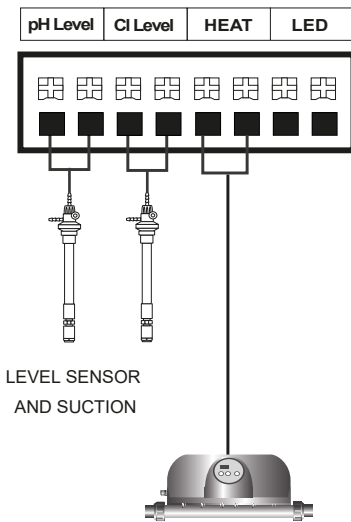

⑤ R1-R4 outputs

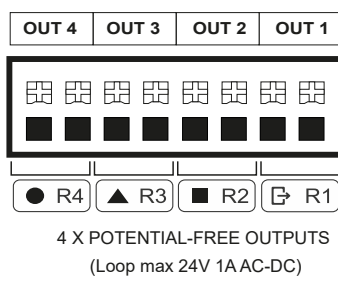

⑥ Modbus

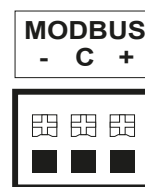

⑦ Interlocks

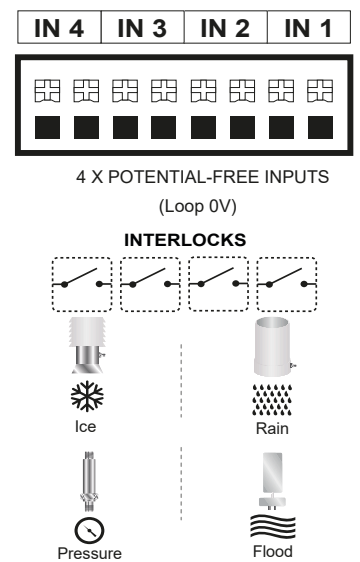

4) VSP driver installation (optional accessory)

The VSP (variable speed pump) driver enables the Filtering function.

Once the VSP driver has been installed, multiple speeds (S1, S2, S3) can be set in R1.

Contents

| PIN | | | | | | |
|---------|---------|-------|-------|-------|-------|-----|
| B1 | B2 | P1 | P2 | P3 | P4 | PG |
| Valve 1 | Valve 2 | Out 1 | Out 2 | Out 3 | Out 4 | Com |

Variable speed pump
0%, S1,S2,S3



1 Open cable channel to access the VSP cable



2 Locate the VSP cable and position it as shown in the photo (red on the right) ■■■■■■



3 Connect the VSP driver pins to the VSP cable. Make sure the connector and pins are positioned correctly ■■■■■■



4 Tighten the two screws and press at the top of the driver to secure it and close the cable channel

ATTENTION:

The cable must be connected with the orientation shown to ensure the equipment functions properly.

Black

Green

Blue

Red

| COMPATIBLE VSP MODELS | |
|-----------------------|---------------------|
| MANUFACTURER | MODEL |
| ASTRAL | Victoria+ Silent Vs |
| ZODIAC | Flopro VS |
| BADU | Eco Touch-pro II |
| BADU | Easyfit Eco |
| BADU | Prime/bronze Eco Vs |
| DAB | E. Swim |
| HAYWARD | Vstd Max Flo |

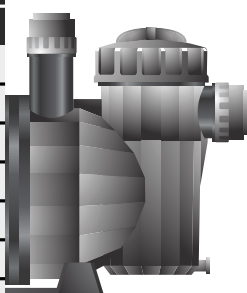

To connect the VSP driver to the pump, the connecting cables must be passed through the feedthroughs at the bottom of the equipment.



5) SD-VSP variable speed pump configuration (S1,S2,S3)

Filter pump status: OFF(0%) / ON: 3 speeds (S1,S2,S3)

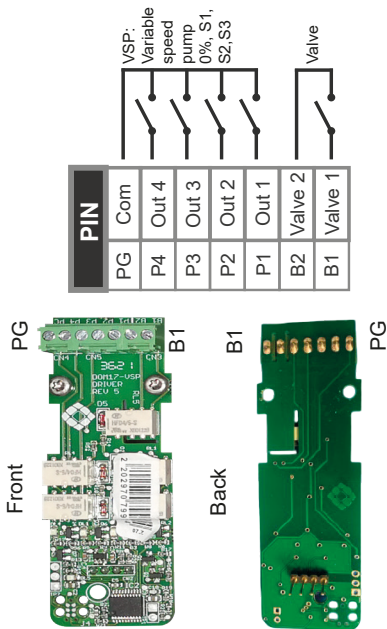
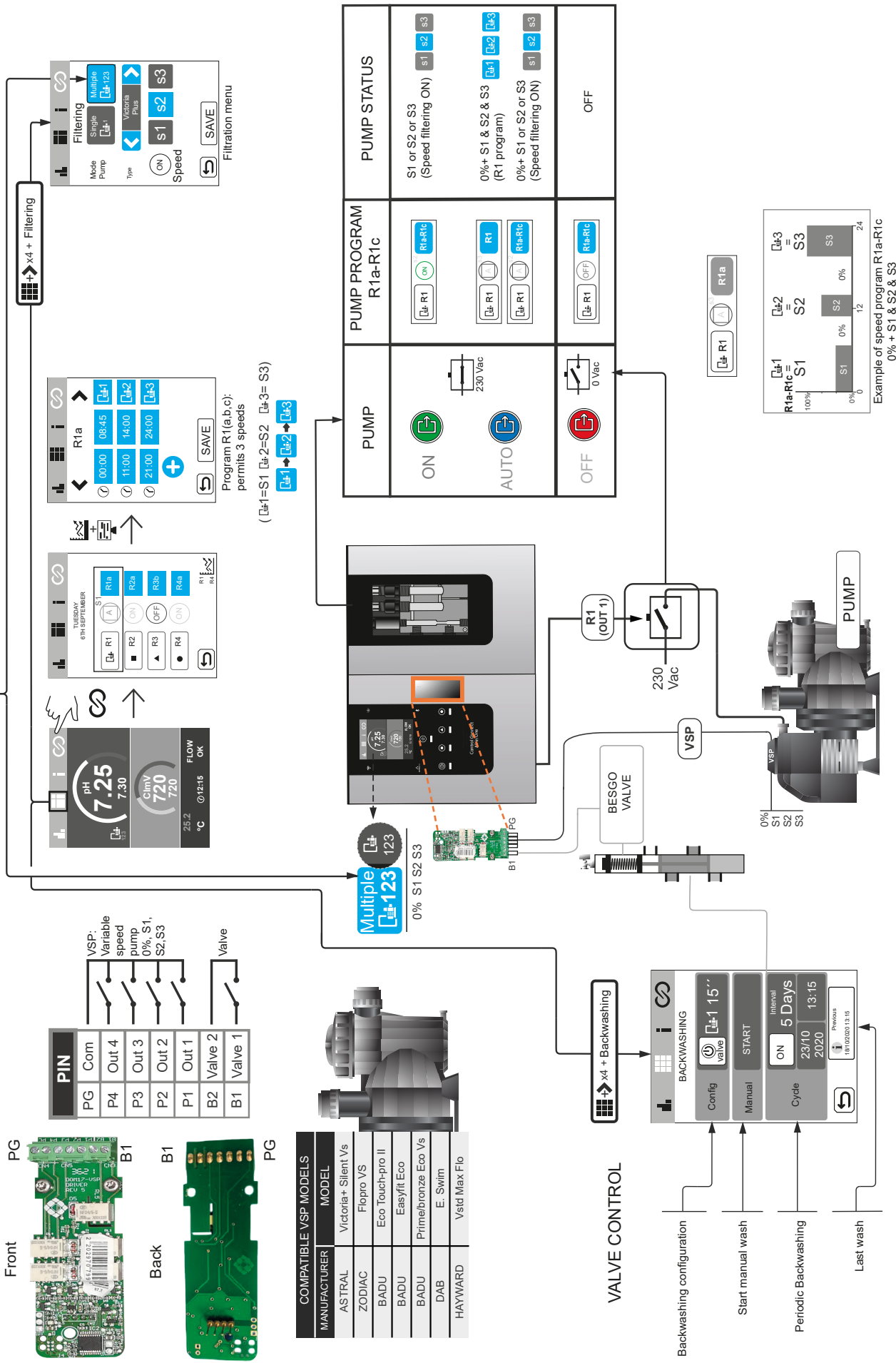

| COMPATIBLE VSP MODELS | MANUFACTURER | MODEL |
|-----------------------|--------------|---------------------|
| | ASTRAL | Victoria+ Silent Vs |
| | ZODIAC | Flopro VS |
| | BADU | Eco Touch-pro II |
| | BADU | Easyfit Eco |
| | BADU | Prime/bronze Eco Vs |
| | DAB | E. Swim |
| | HAYWARD | Vaid Max Flo |

VALVE CONTROL

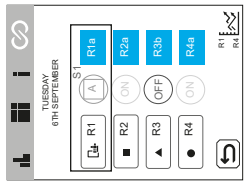
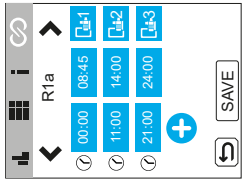
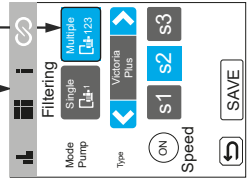
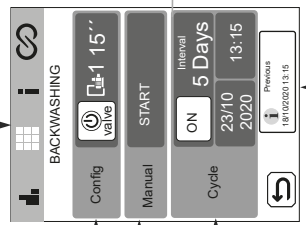

Program R1(a,b,c) permits 3 speeds (S1=S1, S2=S2, S3=S3)

(S1=S1, S2=S2, S3=S3)

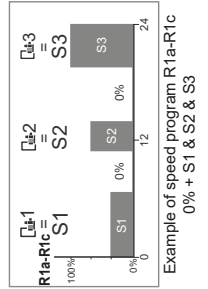
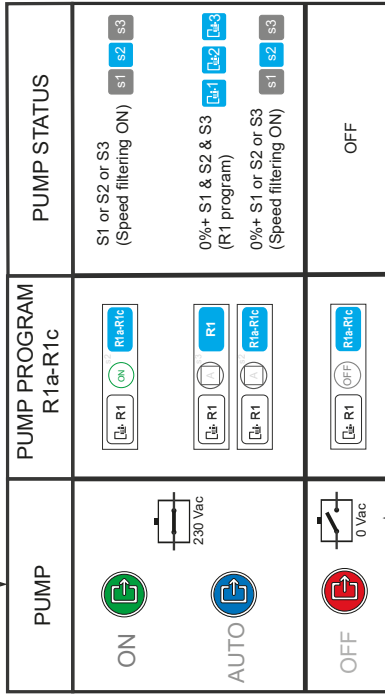

10. Warranty

GENERAL CONSIDERATIONS

- In accordance with these conditions, the seller guarantees that the product covered by this guarantee conforms to its specifications at the moment of its delivery.
- The warranty period of the product is that which is determined by the legal requirements of the country in which the product was acquired by the consumer.
- The warranty period will be calculated from the date of delivery to the purchaser.

Specific warranties:

*The pH sensors are covered by a 2-YEAR warranty without extensions.

*The ORP sensors are covered by a 1-YEAR warranty without extensions.

*These specific warranty periods are particularly subject to the limitations set out in the "LIMITATIONS" section.

- If the Product fails compliance and the purchaser informs the seller during the Warranty Period, the seller shall repair or replace the Product, at its own expense, in the place that they deem appropriate, unless this proves impossible or involves a disproportionate effort.
- If the Product cannot be repaired or replaced, the purchaser may request a proportional reduction in the price, or, if the compliance failure is sufficiently important, the termination of the sales contract.
- All parts replaced or repaired under this warranty will not extend the warranty period of the original Product, although they will be covered by their own warranty.
- In order for this warranty to be effective, the purchaser will provide proof of the date of purchase and delivery of the Product.
- When more than six months have elapsed since the delivery date of the Product to the purchaser, and if the purchaser claims a compliance failure of said Product, the purchaser shall provide evidence of the origin and the existence of the alleged fault.
- This Warranty Certificate does not limit nor prejudice any consumer rights under other national laws in force.

SPECIFIC CONDITIONS

- For this warranty to be effective, the purchaser shall strictly adhere to the Manufacturer's instructions included in the documentation provided with the Product, whenever these are applicable according to the Product range and model.
- When a schedule has been set for the replacement, maintenance or cleaning of certain Product parts or components, the warranty will only be valid if said schedule has been duly adhered to.

LIMITATIONS

- This warranty will only be applicable for sales made to consumers. By "consumer", we refer to any individual who acquires the Product for any purpose that falls outside their professional activity.
- No guarantee is offered for normal product wear, nor for any fungible parts, components, materials or consumables.
- The warranty does not cover instances where the Product: (1) has been misused; (2) has been inspected, repaired, maintained or manipulated by unauthorised personnel; (3) has been repaired or maintained with non-original parts or (4) has been incorrectly installed or commissioned.
- When compliance failure of the Product is due to incorrect installation or commissioning, this warranty will only be effective if such installation or commissioning process is included in the sales contract of the Product and has been performed by the seller, or under the seller's responsibility.
- Damages or fault in the Product due to any of the following causes:
 1. Inadequate system programming and/or calibration of the pH/ORP sensors by the user.
 2. Use of chemicals that have not been specifically authorised.
 3. Exposure to corrosive environments and/or temperatures below 0 °C or above 50 °C.

Copyright © 2025 I.D. Electroquímica, S.L.

All rights reserved. IDEGIS is a registered trademark of I.D. Electroquímica, S.L. in the EU. Modbus is a registered trademark of Modbus Organization, Inc. Any other names or products, trademarks or companies may be trademarks or denominations registered by their respective owners.

