

OCTEO

AUTOMATIC SAFETY COVER - ABOVE GROUND MODEL TECHNICAL INFORMATIONS

DIMENSIONS

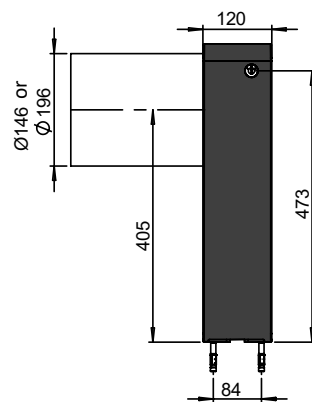
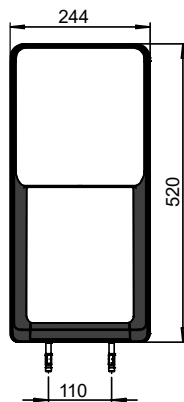
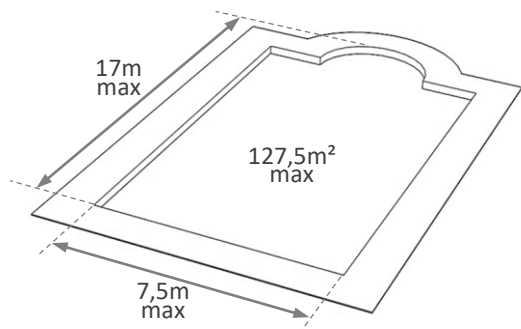

Rolled up cover Ø (cm)	Internal length of the pool (m)														
	3	4	5	6	7	8	9	10	11	12	13	14	15	16	17
	34	37	40	43	46	48	51	53	55	58	60	62	64	65	67

Roller weight (kg)	Internal width of the pool (m)					
	3,03	4,03	5,03	6,03	7,03	7,5
	46	49	52	55	58	65

PACKAGE

Weight of the cover: 4,2kg/m².
The roller comes in a wooden box 80 x 60 x (3,6 to 8,6m max).

MASONRY

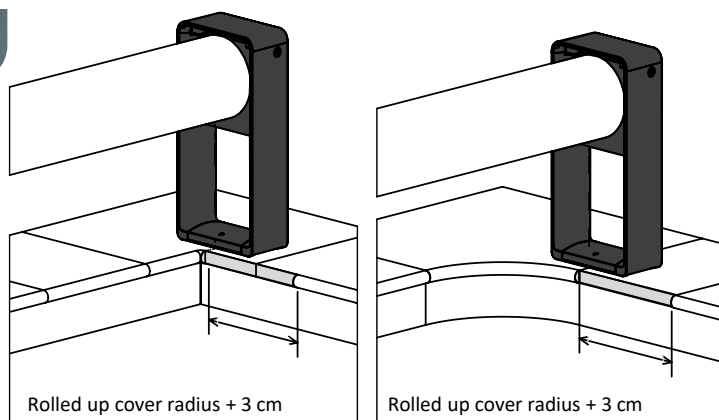
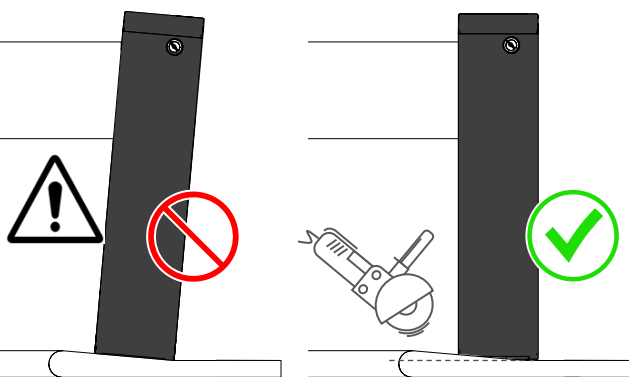

CONNECTIONS

Run a Ø50 mm conduit in order to provide the power supply to the roller.

Power cable depending on the distance D from the motor to the power supply			Chlorinator cable
D < 15m	15m < D < 25m	25m < D < 50m	
2 x 4mm ²	2 x 6mm ²	2 x 10mm ²	3 x 1,5mm ²